

**DEPARTMENT OF ELECTRICAL AND ELECTRONICS  
ENGG.  
BEE047-POWER SYSTEM OPERATION AND  
CONTROL**

---

**UNIT 1-POWER SYSTEM OPERATION AN CONTROL**

**OVERVIEW OF POWER SYSTEM CONTROL:**

- Speed regulation of the governor
- Controls the boiler pressure, temperature & flows
- Speed regulation concerned with steam input to turbine
- Load is inversely proportional to speed
- Governor senses the speed & gives command signal
- Steam input changed relative to the load requirement.

**Governor Control**

Governor is A device used to control the speed of a prime mover. A governor protects the prime mover from overspeed and keeps the prime mover speed at or near the desired revolutions per minute. When a prime mover drives an alternator supplying electrical power at a given frequency, a governor must be used to hold the prime mover at a speed that will yield this frequency. An unloaded diesel engine will fly to pieces unless it is under governor control.

**Load frequency control**

1. Sense the bus bar frequency & power frequency
2. Difference fed to the integrator & to speed changer
3. Tie line frequency maintained constant

**Economic dispatch control**

1. When load distribution between a number of generator units considered optimum schedule affected when increase at one replaces a decreases at other.
2. Optimum use of generators at each station at various load is known as economic dispatch control.

**Automatic voltage regulator**

1. Regulate generator voltage and output power
2. Terminal voltage & reactive power is also met

## **System voltage control**

Control the voltage within the tolerable limits. Devices used are

1. Static VAR compensator
2. Synchronous condenser
3. Tap changing transformer
4. Switches
5. Capacitor
6. Reactor

## **Security control**

1. Monitoring & decision
2. Control

## **Monitoring & decision:**

1. Condition of the system continuously observed in the control centers by relays.
2. If any continuous severe problem occurs system is in abnormal condition.

## **Control:**

1. Proper commands are generated for correcting the abnormality in protecting the system
2. If no abnormality is observed, then the normal operation proceeds for next interval.
3. Central controls are used to monitor the interconnected areas
4. Inter connected areas can be tolerate larger load changes with smaller frequency deviations
5. Central control centre monitors information about frequency, generating unit outputs and tie line power flows to interconnected areas.
6. This information is used by automation load frequency control in order to maintain area frequency at its scheduled value.

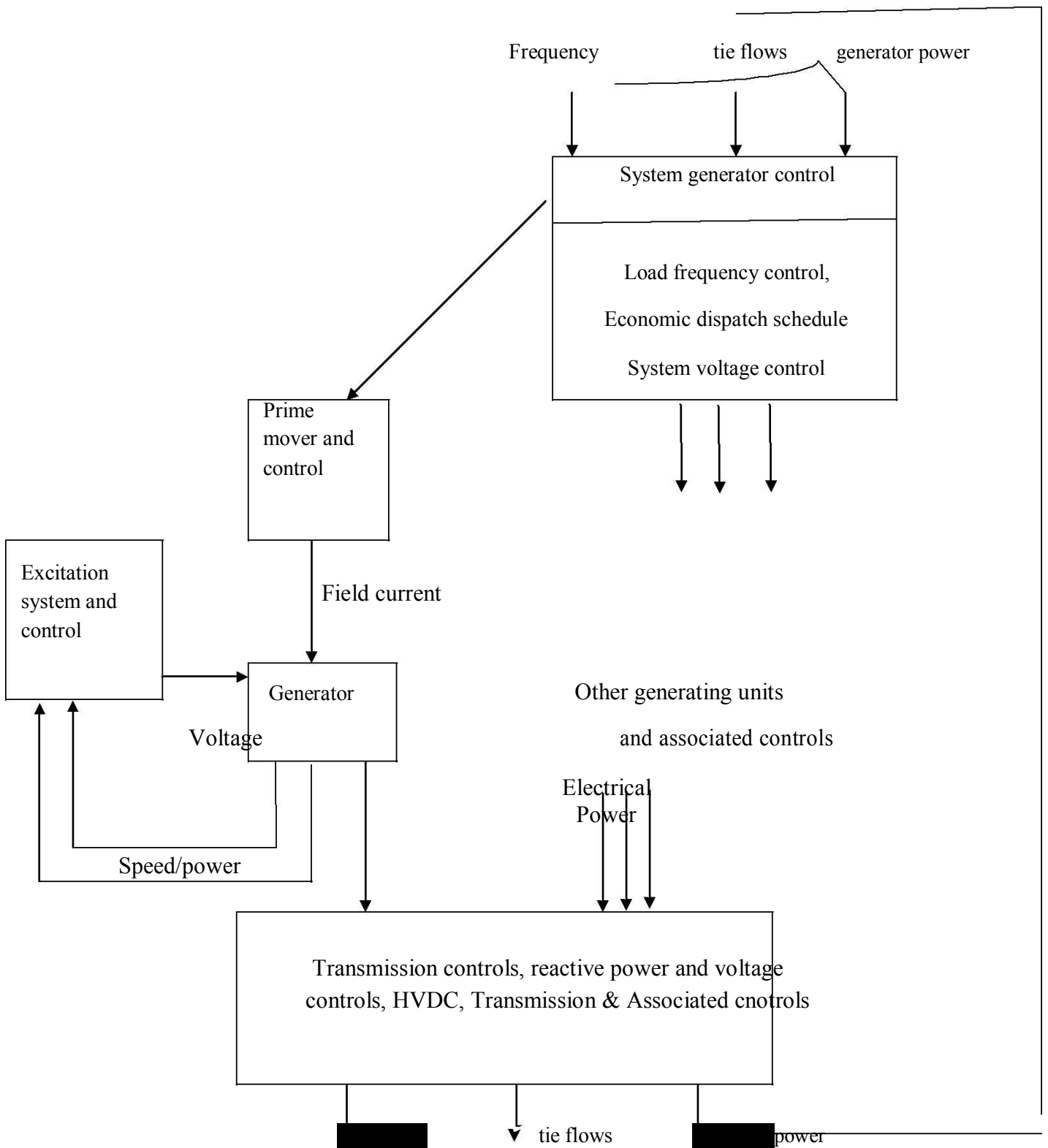

**Overview of system operation and control**

## **Governor:**

The power system is basically dependent upon the synchronous generator and its satisfactory performance. The important control loops in the system are:

- (i) Frequency control, and
- (ii) Automatic voltage control.

Frequency control is achieved through generator control mechanism. The governing systems for thermal and hydro generating plants are different in nature since, the inertia of water that flows into the turbine presents additional constraints which are not present with steam flow in a thermal plant. However, the basic principle is still the same; i.e. the speed of the shaft is sensed and compared with a reference, and the feedback signal is utilized to increase or decrease the power generated by controlling the inlet valve to turbine of steam or water

## **Speed Governing Mechanism**

The speed governing mechanism includes the following parts.

### **Speed Governor:**

It is an error sensing device in load frequency control. It includes all the elements that are directly responsive to speed and influence other elements of the system to initiate action.

### **Governor Controlled Valves:**

They control the input to the turbine and are actuated by the speed control mechanism.

### **Speed Control Mechanism:**

It includes all equipment such as levers and linkages, servomotors, amplifying devices and relays that are placed between the speed governor and the governor controlled valves.

### **Speed Changer:**

It enables the speed governor system to adjust the speed of the generator unit while in operation.



## **P-F AND Q-V CONTROL STRUCTURE**

### **Q-V CONTROL LOOP**

The automatic voltage regulator circuit is used for voltage control. This bus bar voltage is stepped down using a potential transformer to a small value of voltage. This is sent to the rectifier circuit which converts AC voltage into DC voltage and a filter circuit is used in this to remove the harmonics. The voltage  $V$ , thus rectified, is compared with a reference voltage  $v_{ref}$  in the comparator and a voltage error signal is generated. The amplified form of this voltage error signal gives a condition for the generator which is stepped up using a transformer and fed to the bus bar. Thus the voltage is regulated and controlled in the control loop circuit.

### **P-F CONTROL LOOP**

#### **Primary ALFC:**

The circuit primarily controls the steam valve leading to the turbine. A speed sensor senses the speed of the turbine. This is compared with a reference speed, governor whose main activity is to control the speed of the steam by closing and opening of the control valve i.e. if the differential speed is low, then the control valve is opened to let out the steam at high speed, thereby increasing turbine's speed and vice versa. The control of speed in turn controls the frequency.

#### **Secondary ALFC:**

The circuit involves a frequency sensor that senses the frequency of the bus bar and compares it with tie line power frequencies in the signal mixer. The output of this is an area control error which is sent to the speed changer through an integrator. The speed changer gives the reference speed to the governor. An integral controller is used to reduce the steady state frequency change to zero. After this part of the circuit, is the introduction of the primary ALFC loop whose function has already been described.

## **SYSTEM LOAD VARIATION**

The variation of load on power station with respect to time.

### **SYSTEM LOAD**

From system's point of view, there are 5 broad categories of loads:

1. Domestic
2. Commercial
3. Industrial
4. Agriculture
5. Others - street lights, traction.

#### **Domestic:**

Lights, fans, domestic appliances like heaters, refrigerators, air conditioners, mixers, ovens, small motors etc.

Demand factor = 0.7 to 1.0; Diversity factor = 1.2 to 1.3; Load factor = 0.1 to 0.15

#### **Commercial:**

Lightings for shops, advertising hoardings, fans, AC etc.

Demand factor = 0.9 to 1.0; Diversity factor = 1.1 to 1.2; Load factor = 0.25 to 0.3

#### **Industrial:**

Small scale industries: 0-20kW

Medium scale industries: 20-

100kW Large scale industries:

above 100kW

Industrial loads need power over a longer period which remains fairly uniform throughout the day

#### **For heavy industries:**

Demand factor = 0.85 to 0.9; Load factor = 0.7 to 0.8

#### **Agriculture:**

Supplying water for irrigation using pumps driven by motors

Demand factor = 0.9 to 1; Diversity factor = 1.0 to 1.5; Load factor = 0.15 to 0.25

#### **Other Loads:**

Bulk supplies, street lights, traction, government loads which have their own peculiar characteristics

### **System load characteristics**

- Connected load
- Maximum demand
- Average load
- Load factor
- Diversity factor
- Plant capacity factor
- Plant use factor

### **Plant Capacity Factor:**

It is the ratio of actual energy produced to the maximum possible energy that could have been produced during a given period.

### **Plant Use Factor:**

It is the ratio of kWh generated to the product of plant capacity and the number of hours for which the plant was in operation.

$$\text{Plant use factor} = \frac{\text{Station output}}{\text{Plant capacity} \times \text{Hours of use}}$$

### **Load duration curve**

When an elements of a load curve are arranged in the order of descending magnitudes.

### **Load curves**

The curve showing the variation of load on the power station with respect to time

### **Types of Load Curve:**

- Daily load curve–Load variations during the whole day
- Monthly load curve–Load curve obtained from the daily load curve
- Yearly load curve–Load curve obtained from the monthly load curve

### **Base Load:**

The unvarying load which occurs almost the whole day on the station

### **Peak Load:**

The various peak demands so load of the station



### Load duration curve:

When an elements of a load curve are arranged in the order of descending magnitudes.

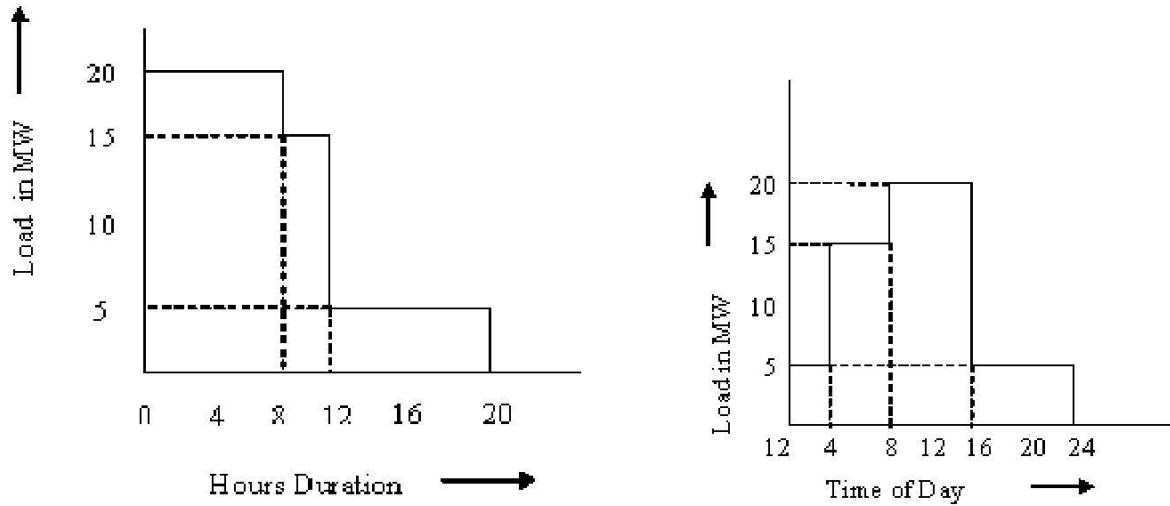

The load duration curve gives the data in a more presentable form

- The area under the load duration curve is equal to that of the corresponding load curve
- The load duration curve can be extended to include any period of time

**Load factor**

The ratio of average load to the maximum demand during a given period is known as load factor.

$$\text{Load factor} = (\text{average load}) / (\text{maximum demand})$$

**Diversity factor**

The ratio of the sum of individual maximum demand on power station is known as diversity factor.

$$\text{Diversity factor} = (\text{sum of individual maximum demand}) / (\text{maximum demand}).$$

---

UNIT – II  
REAL POWER AND  
FREQUENCY CONTROL

## TECHNICAL TERMS

**Control area:** Most power systems normally control their generators in unison. The individual control loops have the same regulation parameters. The individual generator turbines tend to have the same response characteristics then it is possible to let the control loop in the whole system which then would be referred to as a control area.

**Power Pool:** An association of two or more interconnected electric systems having an agreement to coordinate operations and planning for improved reliability and efficiencies.

**Prime Mover:** The engine, turbine, water wheel, or similar machine that drives an electric generator; or, for reporting purposes, a device that converts energy to electricity directly (e.g., photovoltaic solar and fuel cell(s)).

**Pumped-Storage Hydroelectric Plant:** A plant that usually generates electric energy during peak-load periods by using water previously pumped into an elevated storage reservoir during off-peak periods when excess generating capacity is available to do so. When additional generating capacity is needed, the water can be released from the reservoir through a conduit to turbine generators located in a power plant at a lower level.

**Regulation:** The governmental function of controlling or directing economic entities through the process of rulemaking and adjudication

**Reserve Margin (Operating):** The amount of unused available capability of an electric power system at peak load for a utility system as a percentage of total capability.

**Restructuring:** The process of replacing a monopoly system of electric utilities with competing sellers, allowing individual retail customers to choose their electricity supplier but still receive delivery over the power lines of the local utility. It includes the reconfiguration of the vertically-integrated electric utility.

**Retail Wheeling:** The process of moving electric power from a point of generation across one or more utility-owned transmission and distribution systems to a retail customer.

**Revenue:** The total amount of money received by a firm from sales of its products and/or services, gains from the sales or exchange of assets, interest and dividends earned on investments, and other increases in the owner's equity except those arising from capital adjustments.

**Scheduled Outage:** The shutdown of a generating unit, transmission line, or other facility, for inspection or maintenance, in accordance with an advance schedule.

**Real power:** The real power in a power system is being controlled by controlling the driving torque of the individual turbines of the system.

## **LOAD FREQUENCY CONTROL**

The following basic requirements are to be fulfilled for successful operation of the system:

1. The generation must be adequate to meet all the load demand
2. The system frequency must be maintained within narrow and rigid limits.
3. The system voltage profile must be maintained within reasonable limits and
4. In case of interconnected operation, the tie line power flows must be maintained at the specified values.

When real power balance between generation and demand is achieved the frequency specification is automatically satisfied. Similarly, with a balance between reactive power generation and demand, voltage profile is also maintained within the prescribed limits. Under steady state conditions, the total real power generation in the system equals the total MW demand plus real power losses. Any difference is immediately indicated by a change in speed or frequency. Generators are fitted with speed governors which will have varying characteristics: different sensitivities, dead bands response times and droops. They adjust the input to match the demand within their limits. Any change in local demand within permissible limits is absorbed by generators in the system in a random fashion.

An independent aim of the automatic generation control is to reschedule the generation changes to preselected machines in the system after the governors have accommodated the load change in a random manner. Thus, additional or supplementary regulation devices are needed along with governors for proper regulation.

The control of generation in this manner is termed load-frequency control. For interconnected operation, the last of the four requirements mentioned earlier is fulfilled by deriving an error signal from the deviations in the specified tie-line power flows to the neighboring utilities and adding this signal to the control signal of the load-frequency control system. Should the generation be not adequate to balance the load demand, it is imperative

that one of the following alternatives be considered for keeping the system in operating condition:

- I. Starting fast peaking units.
2. Load shedding for unimportant loads, and
3. Generation rescheduling.

It is apparent from the above that since the voltage specifications are not stringent. Load frequency control is by far the most important in power system control.

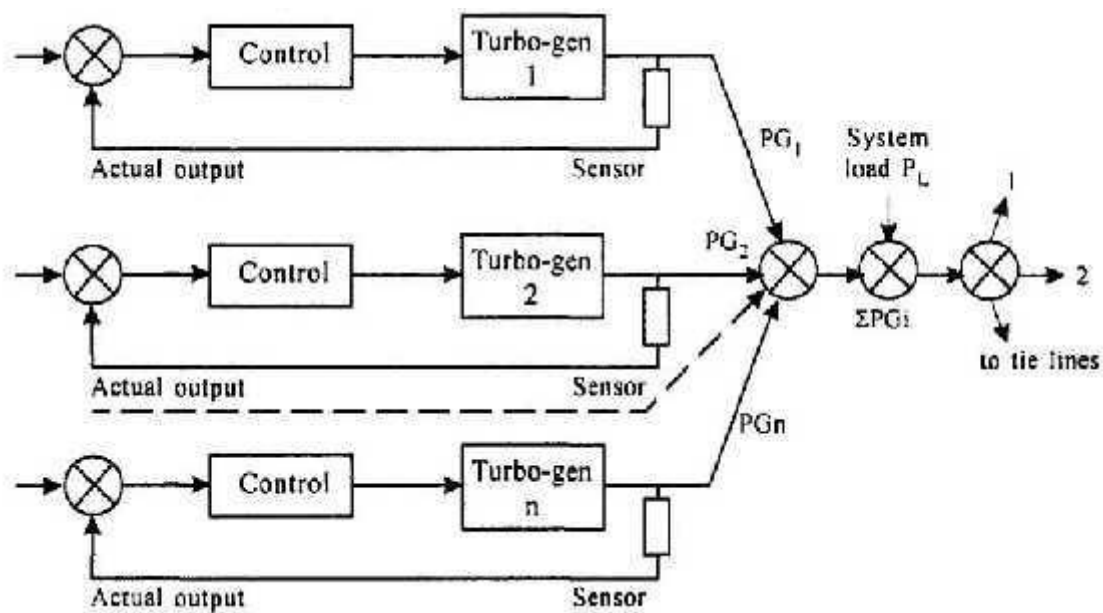

### The block schematic for Load frequency control

In order to understand the mechanism of frequency control, consider a small step increase in load. The initial distribution of the load increment is determined by the system impedance; and the instantaneous relative generator rotor positions. The energy required to supply the load increment is drawn from the kinetic energy of the rotating machines. As a result, the system frequency drops. The distribution of load during this period among the various machines is determined by the inertias of the rotors of the generators partaking in the process. This problem is studied in stability analysis of the system.

After the speed or frequency fall due to reduction in stored energy in the rotors has taken place, the drop is sensed by the governors and they divide the load increment between the machines as determined by the droops of the respective governor characteristics. Subsequently, secondary control restores the system frequency to its normal value by readjusting the governor characteristics.

## AUTOMATIC LOAD FREQUENCY CONTROL

The ALFC is to control the frequency deviation by maintaining the real power balance in the system. The main functions of the ALFC are to i) to maintain the steady frequency; ii) control the tie-line flows; and iii) distribute the load among the participating generating units. The control (input) signals are the tie-line deviation  $\Delta P_{tie}$  (measured from the tie-line flows), and the frequency deviation  $\Delta f$  (obtained by measuring the angle deviation  $\Delta\delta$ ). These error signals  $\Delta f$  and  $\Delta P_{tie}$  are amplified, mixed and transformed to a real power signal, which then controls the valve position. Depending on the valve position, the turbine (prime mover) changes its output power to establish the real power balance. The complete control schematic is shown in Fig3.3

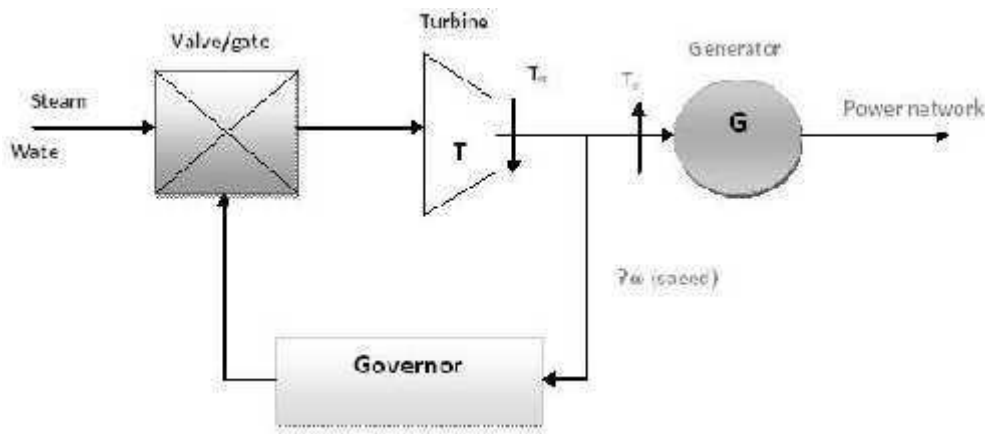

### The Schematic representation of ALFC system

For the analysis, the models for each of the blocks in Fig2 are required. The generator and the electrical load constitute the power system. The valve and the hydraulic amplifier represent the speed governing system. Using the swing equation, the generator can be modeled by

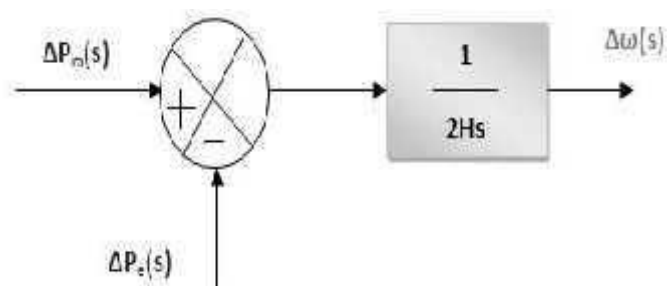

## Block Diagram Representation Of The Generator

The load on the system is composite consisting of a frequency independent component and a frequency dependent component. The load can be written as  $P_e = P_0 + P_f$

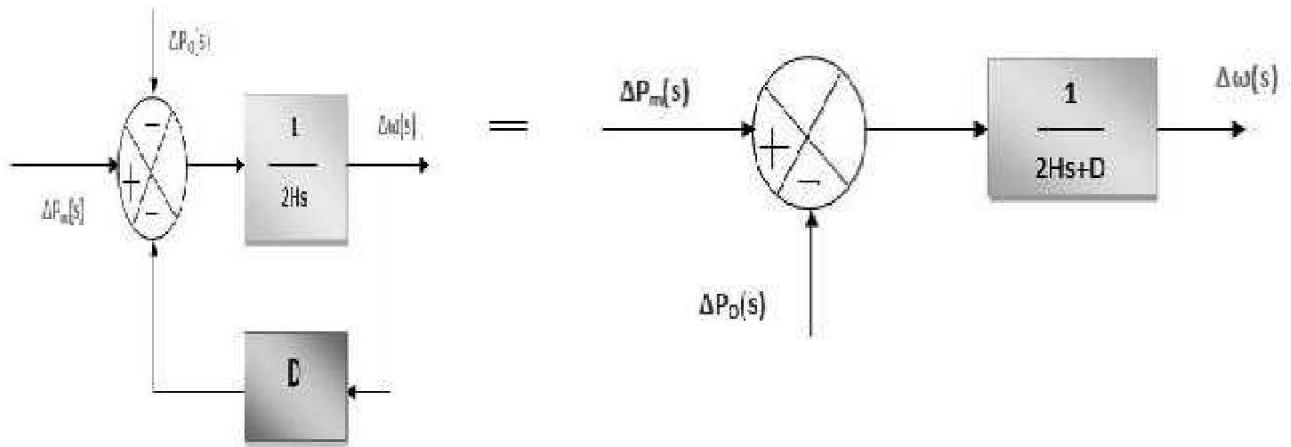

## Block Diagram Representation Of The Generator And Load

where,  $P_e$  is the change in the load;  
 $P_0$  is the frequency independent load component;  $P_f$  is the frequency dependent load component.

$P_f = D$  where,  $D$  is called frequency characteristic of the load (also called as damping constant) expressed in percent change in load for 1% change in frequency. If  $D=1.5\%$ , then a

1% change in frequency causes 1.5% change in load. The combined generator and the load (constituting the power system) can then be represented as shown in Fig3.5

The turbine can be modeled as a first order lag as shown in the Fig2.6

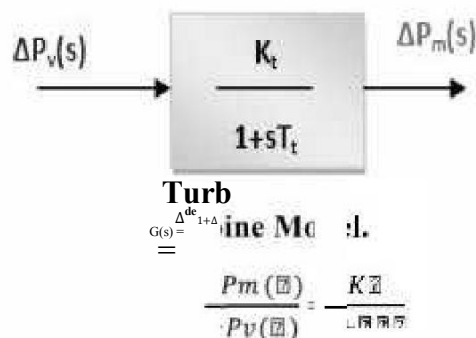



$G_t(s)$  is the TF of the turbine;  $\Delta P_V(s)$  is the change in valve output (due to action).  $P_m(s)$  is the change in the turbine output

The governor can similarly modeled as shown in fig 2F.7. The output of the governor is by

Where  $\Delta P_{ref}$  is the reference set power, and  $\Delta w/R$  is the power given by governor speed characteristic. The hydraulic amplifier transforms this signal  $P_g$  into valve/gate position corresponding to a power  $P_V$ .

Thus

$$P_V(s) = (K_g / (1+sT_g)) \Delta P_g(s).$$

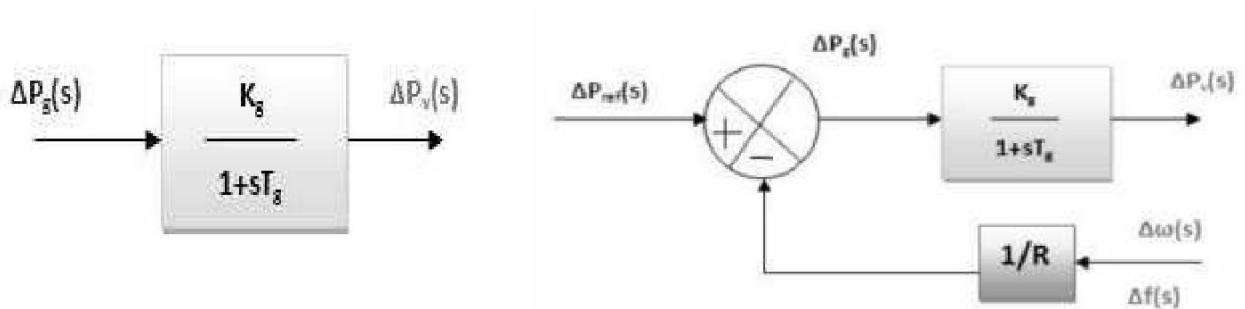

**Block Diagram Representation Of The Governor**

**LFC control of single area and derive the steady state frequency error.**

All the individual blocks can now be connected to represent the complete ALFC loop as

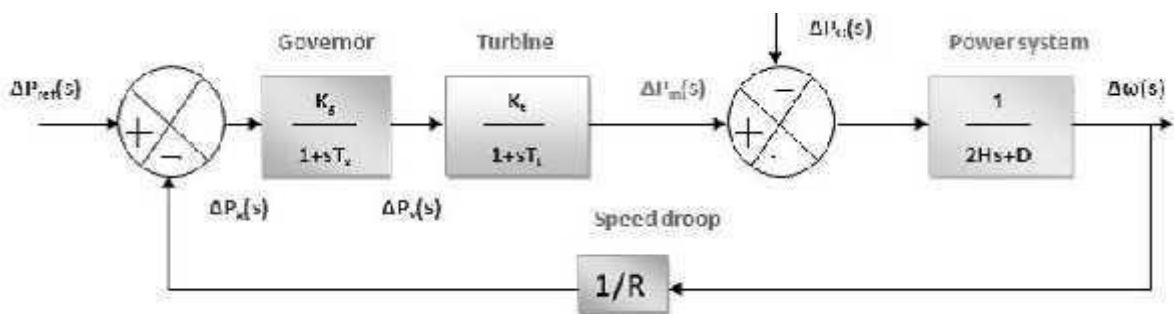

**Block diagram representation of the ALFC**

**Static Power Generation**

We have

$$\Delta P_G(s) = k_G k_t / (1+sT_G)(1+sT_t) [\Delta P_c(s) - 1/R \Delta F(s)]$$

The generator is synchronized to a network of very large size. So, the speed or frequency will be essentially independent of any changes in a power output of the generator

ie,  $\Delta F(s) = 0$

$$\text{Therefore } \Delta P_G(s) = k_G k_t / (1+sT_g) (1+sT_t) * \Delta P_c(s)$$

Steady state response

**(i) Controlled case:**

To find the resulting steady change in the generator output:

Let us assume that we made a step change of the magnitude  $\Delta P_c$  of the speed changer. For step change,  $\Delta P_c(s) = \Delta P_c/s$

$$\Delta P_G(s) = k_G k_t / (1+sT_g) (1+sT_t) \cdot \Delta P_c(s)/s$$

$$s\Delta P_G(s) = k_G k_t / (1+sT_g) (1+sT_t) \cdot \Delta P_c(s)$$

Applying final value theorem,

$$\Delta P_{G(\text{stat})} = \Delta$$

**(ii) Uncontrolled case**

Let us assume that the load suddenly increases by small amount  $\Delta P_D$ . Consider there is no external work and the generator is delivering a power to a single load.

$$\text{Since } \Delta P_c = 0, k_G k_t = 1$$

It has been shown that the load frequency control system possesses inherently steady state error for a step input. Applying the usual procedure, the dynamic response of the control loop can be evaluated so that the initial response also can be seen for any overshoot.

For this purpose considering the relatively larger time constant of the power system the governor action can be neglected, treating it as instantaneous action. Further the turbine generator dynamics also may be neglected at the first instant to derive a simple expression for the time response

$\Delta P_G(s) = 1/(1+sT_G)(1+sT_t) [-\Delta F(s)/R]$  For a

step change  $\Delta F(s) = \Delta f/s$  Therefore

$$\Delta P_G(s) = 1/(1+sT_G)(1+sT_t) [-\Delta F/sR]$$

$$\Delta f/\Delta P_G(\text{stat}) = -R \text{ Hz/MW}$$

### Steady State Performance of the ALFC Loop

In the steady state, the ALFC is in 'open' state, and the output is obtained by substituting  $s \rightarrow 0$  in the TF.

With  $s \rightarrow 0$ ,  $G_g(s)$  and  $G_t(s)$  become unity, then, (note that  $\Delta P_m = \Delta P_T = P_G = \Delta P_e = \Delta P_D$ ;

That is turbine output = generator/electrical output = load demand)

$$\Delta P_m = \Delta P_{\text{Pref}} - (1/R) \Delta \omega \text{ or } \Delta P_m = \Delta P_{\text{Pref}} - (1/R) \Delta f$$

When the generator is connected to infinite bus ( $\Delta f = 0$ , and  $\Delta V = 0$ ), then  $\Delta P_m = \Delta P_{\text{Pref}}$ .

If the network is finite, for a fixed speed changer setting ( $\Delta P_{\text{Pref}} = 0$ ), then

$$\Delta P_m = (1/R) \Delta f \text{ or } \Delta f = R \Delta P_m.$$

### Concept of AGC (Supplementary ALFC Loop)

The ALFC loop shown in is called the primary ALFC loop. It achieves the primary goal of real power balance by adjusting the turbine output  $\Delta P_m$  to match the change in load demand  $\Delta P_D$ . All the participating generating units contribute to the change in generation. But a change in load results in a steady state frequency deviation

$\Delta f$ . The restoration of the frequency to the nominal value requires an additional control loop called the supplementary loop. This objective is met by using integral controller which makes the frequency deviation zero. The ALFC with the supplementary loop is generally called the AGC. The block diagram of an AGC is shown in Fig3.9. The main objectives of AGC are i) to regulate the frequency (using both primary and supplementary controls); ii) and to maintain the scheduled tie-line flows. A secondary objective of the AGC is to distribute the required change in generation among the connected generating units economically (to obtain least operating costs).

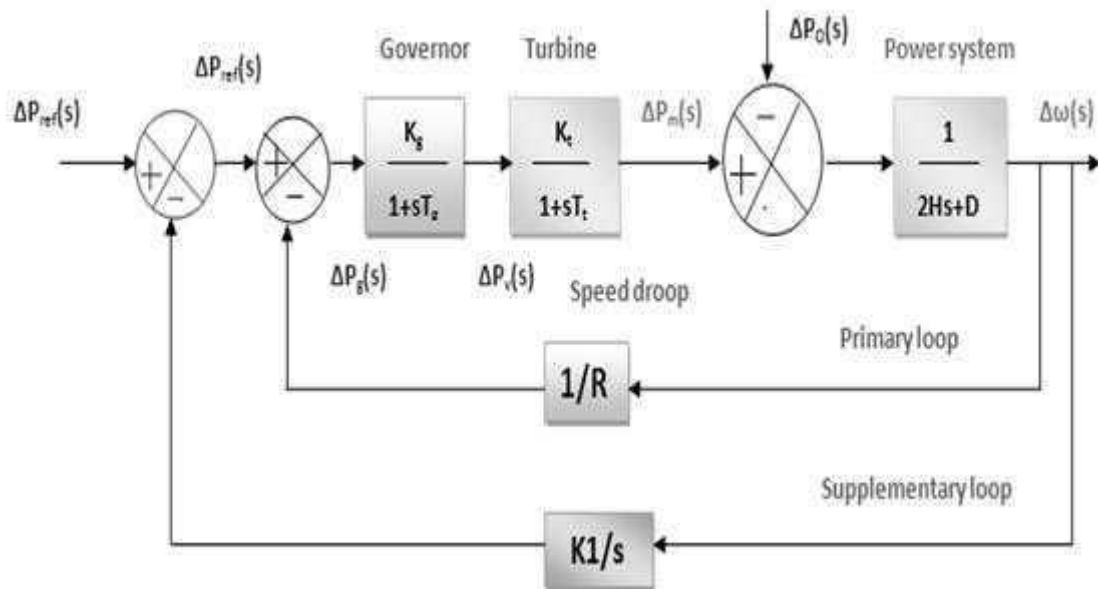

**Block diagram representation of the AGC**

### AGC in a Single Area System

In a single area system, there is no tie-line schedule to be maintained. Thus the function of the AGC is only to bring the frequency to the nominal value. This will be achieved using the supplementary loop (as shown in Fig.3.9) which uses the integral controller to change the reference power setting so as to change the speed set point.

The integral controller gain  $KI$  needs to be adjusted for satisfactory response (in terms of overshoot, settling time) of the system. Although each generator will be having a separate speed governor, all the generators in the control area are replaced by a single equivalent generator, and the ALFC for the area corresponds to this equivalent generator.

### Dynamic Response of the One-Area System

Now we are going to study the effect of a disturbance in the system derived above. Both loss of generation and loss of load can be simulated by imposing a positive or negative step input on the variable  $P_{load}$ . A change of the set value of the system frequency  $f_0$  is not considered as this is not meaningful in real power systems. From the block diagram in Figure 3.9 it is straightforward to derive the transfer function between

$$\Delta P_{load} \text{ and } \Delta f \ (\Delta P_{load} - 0)$$

$$\Delta f(s) = \frac{1}{s} + \frac{1}{D_t} (1 + sT_t) + \left( \frac{2W_0}{f_0} + \frac{2HS_R}{f_0} \right) s (1 + sT_t) \Delta P_{load}(s)$$

The step response for

$$\Delta P_{load}(s) = \frac{\Delta P_{load}}{s}$$

$$\Delta f_{\infty} = \lim_{s \rightarrow 0} (s \cdot \Delta f(s)) = \frac{\Delta P_{load}}{\frac{1}{s} + \frac{1}{D_t}} = \frac{\Delta P_{load}}{\frac{1}{D_t}} = \Delta P_{load} \cdot D_t$$

with

$$\frac{1}{D_t} = \frac{1}{s} + \frac{1}{D_R}$$

In order to calculate an equivalent time constant  $T_{eq}$ ,  $T_t$  is put to 0. This can be done since for realistic systems the turbine controller time constant  $T_t$  is much smaller than the time constant

### AGC IN A MULTI AREA SYSTEM

In an interconnected (multi area) system, there will be one ALFC loop for each control area (located at the ECC of that area). They are combined as shown in Fig2.10 for the interconnected system operation. For a total change in load of  $\Delta P_D$ , the steady state Consider a two area system as depicted in Figure 3.10. The two secondary frequency controllers, AGC1 and AGC2, will adjust the power reference values of the generators participating in the AGC. In an N-area system, there are N controllers AGC<sub>i</sub>, one for each area

A block diagram of such a controller is given in Figure 4.2. A common way is to implement this as a proportional-integral (PI) controller:

Deviation in frequency in the two areas is given by

$$\Delta f = \Delta \omega_1 = \Delta \omega_2$$

$$\beta_1 = D_1 + 1/R_1$$

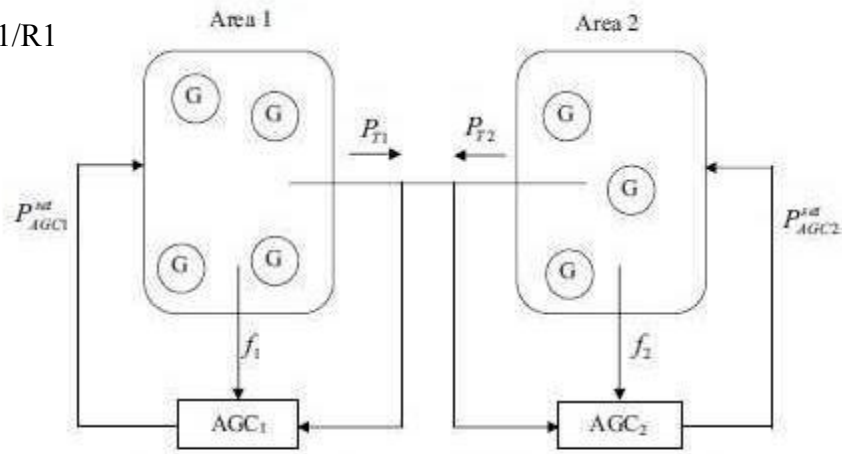

$$P_{T1} = \text{Tie line power for Area 1} = \sum_{j=1}^n P_{T1}^j = \text{Sum over all tie lines}$$

Substituting these equations, yields

$$(1/R_1 + D_1) \Delta f = -\Delta P_{12} - \Delta P_m$$

$$(1/R_2 + D_2) \Delta f = -\Delta P_{12} - \Delta P_m$$

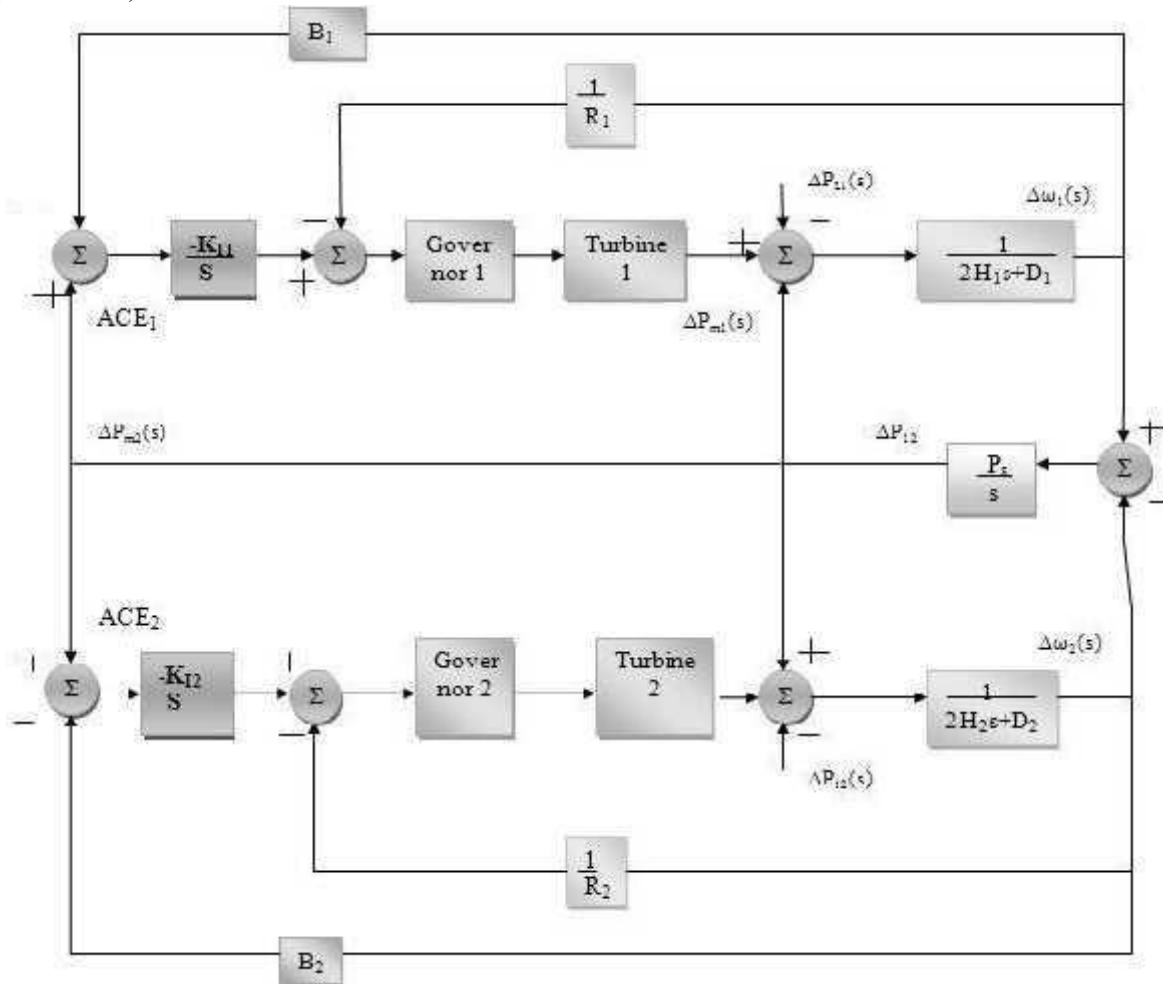

**A G C for a multi-area operation**

## DYNAMIC RESPONSE OF LOAD FREQUENCY CONTROL LOOPS

It has been shown that the load frequency control system possesses inherently steady state error for a step input. Applying the usual procedure, the dynamic response of the control loop can be evaluated so that the initial response also can be seen for any overshoot.

For this purpose considering the relatively larger time constant of the power system the governor action can be neglected, treating it as instantaneous action. Further the turbine generator dynamics also may be neglected at the first instant to derive a simple expression for the time response.

It has been proved that

$$\Delta F(S) = - \frac{G_p}{1 + \frac{1}{R} G_s G_{LG} G_T} \Delta P_D(S)$$

For a step load change of magnitude k

$$\Delta P_D(S) = \frac{-k}{S}$$

Neglecting the governor action and turbine dynamics

$$\Delta F(S) = - \frac{G_p}{1 + \frac{1}{R} G_p} \frac{k}{S}$$

$$= - \left( \frac{K_p}{1 + ST_p} \right) \left( \frac{1}{1 + \frac{1}{R} \frac{K_p}{1 + ST_p}} \right) \frac{k}{S}$$

Applying partial fractions

$$\Delta F(S) = \frac{K_p k}{T_f} \left[ \frac{1}{S \left[ S + \left( \frac{1}{T_p} + \frac{K_p}{RT_p} \right) \right]} \right] - \frac{K_p k}{T_f} \left[ \frac{1}{S \left[ S - \frac{1}{T_p} + \frac{K_p}{RT_f} \right]} \right]$$



## INTERCONNECTED OPERATION

Power systems are interconnected for economy and continuity of power supply. For the interconnected operation incremental efficiencies, fuel costs. Water availability, generation limits, tie line capacities, spinning reserve allocation and area commitment's are important considerations in preparing load dispatch schedules.

### Flat Frequency Control of Inter-connected Stations

Consider two generating stations connected by a tie line as in Fig3.12. For a load increment on station B, the kinetic energy of the generators reduces to absorb the same. Generation increases in both the stations A and B, and frequency will be less than normal at the end of the governor response period. The load increment will be supplied partly by A and partly by B. The tie line power flow will change thereby. If a frequency controller is placed at B, then it will shift the governor characteristic at B parallel to itself as shown in Fig and the frequency will be restored to its normal value  $f_s'$  reducing the change in generation in A to zero.

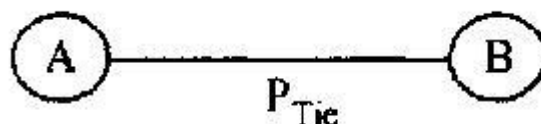

**Figure 3.12. Two area with tie line power**

Assumption in Analysis:

The following assumptions are made in the analysis of the two area system:

1. The overall governing characteristic of the operating units in any area can be represented by  
a linear curve of frequency versus generation.
2. The governors in both the areas start acting simultaneously to changes in their respective areas.
3. Supplementary control devices act after the initial governor response is over

The following time instants are defined to explain the control sequence:

$T_0$  = is the instant when both the areas are operating at the scheduled frequency and Tie = line interchange and load change takes place.

$t_1$  = the instant when governor action is initiated at both A and B.

$t_2$  = the instant when governor action ceases.

t3 = the instant when regulator action begins.

t4 = the instant when regulator action ceases.

While the initial governor response is the same as for the previous case, the action of the controller in B will force the generation in area B to absorb the load increment in area A. When the controller begins to act at t3, the governor characteristic is shifted parallel to itself in B till the entire load increment in A is absorbed by B and the frequency is restored to normal. Thus, in this case while the frequency is regulated on one hand, the tie-line schedule is not maintained on the other hand.

If area B, which is in charge of frequency regulation, is much larger than A, then load changes in A will not appreciably affect the frequency of the system. Consequently, it can be said that flat frequency control is useful only when a small system is connected to a much larger system.

### 3.10.4. Two Area Systems - Tie-Line Power Model:

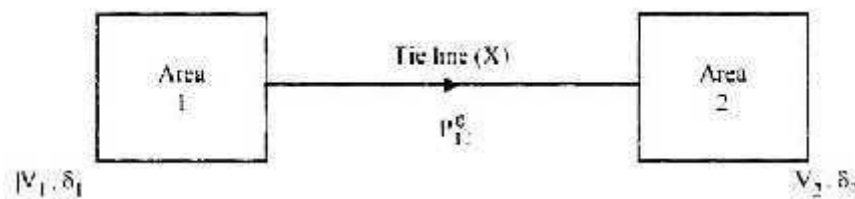

Two Area Systems - Tie-Line Power

Consider two inter connected areas as shown in figure operating at the same frequency  $f$  while a power flow from area 1 to area 2

let  $V_1$  and  $V_2$  be the voltage magnitudes

$\delta_1, \delta_2$  voltage phase angles at the two ends of the tie-

line. While  $P$  flows from area 1 to area 2 then,

$$P_{12}^e = \frac{|V_1||V_2|}{X} \sin(\delta_1^e - \delta_2^e)$$

Where  $X$  is the reactance of the line. If the angles change by  $\Delta\delta_1$  and  $\Delta\delta_2$  due to load changes in areas 1 and 2 respectively. Then, the tie-line power changes by

$$\frac{\Delta P_{12}}{\Delta\delta - \Delta\delta_2} = \frac{\Delta P_{12}}{\Delta\delta} \text{ MW/radian}$$

$$\Delta P_{12} = T^0 (\Delta\delta_1^0 - \Delta\delta_2^0)$$

$$\Delta\omega = \frac{d}{dt} \Delta\delta$$

Block diagram for tie-line power

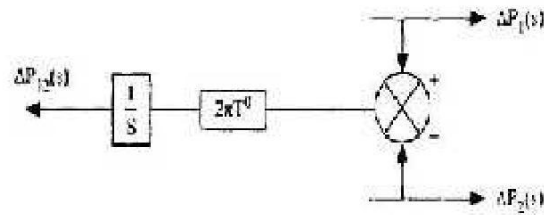

$$\frac{P_{r1}}{P_{r2}} = a_{12}$$

$$\Delta P_{21}(s) = \frac{2\pi T_{21}^o}{s} [\Delta F_2(s) - \Delta F_1(s)]$$

$$\frac{2\pi T_{21}^o}{s} a_{12} [\Delta F_1(s) - \Delta F_2(s)]$$

### Dynamic Response:

Let us now turn our attention during the transient period for the sake of simplicity. We shall assume the two areas to be identical. Further we shall be neglecting the time constants of generators and turbines as they are negligible as compared to the time constants of power systems. The equation may be derived for both controlled and uncontrolled cases. There are four equations with four variables, to be determined for given PD1 and PD2. The dynamic response can be obtained; even though it is a little bit involved. For simplicity assume that the two areas are equal. Neglect the governor and turbine dynamics, which means that the dynamics of the system under study is much slower than the fast acting turbine-governor system in a relative sense. Also assume that the load does not change with frequency ( $D_1 = D_2 = 0$ ).

$$\left\{ -\frac{1}{R_1} \Delta F_1(s) \left[ \frac{K_S}{1 + ST_{S1}} \right] \left[ \frac{K_{TG1}}{1 + ST_{TG2}} \right] - \Delta P_{D1}(s) - \Delta P_{12}(s) \right\} \frac{K_{P1}}{1 + ST_{P1}} = \Delta F_1(s)$$

$$\left\{ -\frac{1}{R_2} \Delta F_2(s) \left[ \frac{K_{S2}}{1 + ST_{S2}} \right] \left[ \frac{K_{TG2}}{1 + ST_{TG2}} \right] - \Delta P_{D2}(s) - \Delta P_{21}(s) \right\} \frac{K_{P2}}{1 + ST_{P2}} = \Delta F_2(s)$$

$$\Delta P_{12}(s) = \frac{2\pi T_{12}^o}{s} [\Delta F_1(s) - \Delta F_2(s)]$$

$$\Delta P_{21}(s) = -\Delta P_{12}(s)$$

We obtain under these assumptions the following relations

$$\begin{aligned} \Delta P_{12}(S) &= \frac{[\Delta P_{D2}(S) - \Delta P_{D1}(S)] \frac{f^0}{2SH}}{\frac{s}{2\pi T^0} + \frac{2f^0}{2\pi T^0} + \frac{Sf^0}{2\pi RT^0 2SH}} \\ &= \frac{[\Delta P_{D2}(S) - \Delta P_{D1}(S)] \frac{\pi f^0 T^0}{SH}}{S + \frac{2f^0 \pi T^0}{SH} + \frac{f^0}{2RH}} \\ &= \frac{\pi f^0 T^0}{H} \frac{[\Delta P_{D2}(S) - \Delta P_{D1}(S)]}{S^2 + \left(\frac{f^0}{2RH}\right)S + \left(\frac{2f^0 \pi T^0}{H}\right)} \end{aligned}$$

The denominator is of the form

$$(s^2 + 2KS + \omega^2) = (s + K)^2 + (\omega^2 - K^2)$$

where  $K = \frac{f^0}{4RH}$  and  $\omega = \sqrt{\frac{2\pi f^0 T^0}{H}}$

setting  $\sqrt{\omega^2 - K^2}$  as  $\omega_0$ ,

$$\omega_0 = \sqrt{\frac{2\pi T^0 f^0}{H} - \left(\frac{f^0}{4RH}\right)^2}$$

hat both K and  $\omega_0$  are positive. From the roots of the characteristic equation we notice that the system is stable and damped. The frequency of the damped oscillations is given by  $\omega_0$ . Since H and  $f_0$  are constant, the frequency of oscillations depends upon the regulation parameter R. Low R gives high K and high damping and vice versa. We thus conclude from the preceding analysis that the two area system, just as in the case of a single area system in the uncontrolled mode, has a steady state error but to a lesser extent and the tie line power deviation and frequency deviation exhibit oscillations that are damped out later.

## **UNIT-III**

### **REACTIVE POWER**

### **VOLTAGE CONTROL**

## **REACTIVE POWER**

Reactive power is an odd topic in AC (Alternating Current) power systems, and it's usually explained with vector mathematics or phase-shift sine wave graphs. However, a non-math verbal explanation is possible. Note that Reactive power only becomes important when an "electrical load" or a home appliance contains coils or capacitors. If the electrical load behaves purely as a resistor, (such as a heater or incandescent bulb for example,) then the device consumes "real power" only. Reactive power and "power factor" can be ignored, and it can be analyzed using an AC version of Ohm's law. Reactive power is simply this: when a coil or capacitor is connected to an AC power supply, the coil or capacitor stores electrical energy during one-fourth of an AC cycle. But then during the next quarter-cycle, the coil or capacitor dumps all the stored energy back into the distant AC power supply.

Ideal coils and capacitors consume no electrical energy, yet they create a significant electric current. This is very different from a resistor which genuinely consumes electrical energy, and where the electrical energy flows continuously in one direction; moving from source to load. In other words, if your electrical appliance contains inductance or capacitance, then electrical energy will periodically return to the power plant, and it will flow back and forth across the power lines. This leads to an extra current in the power lines, a current which heats the power lines, but which isn't used to provide energy to the appliance. The coil or capacitor causes electrical energy to begin "sloshing" back and forth between the appliance and the distant AC

Generator. Electric companies must install heavier wires to tolerate the excess current, and they will charge extra for this "unused" energy. This undesired "energy sloshing" effect can be eliminated. If an electrical load contains both a coil and capacitor, and if their resonant frequency is adjusted to exactly 60Hz, then the coil and capacitor like magic will begin to behave like a pure resistor. The "energy sloshing" still occurs, but now it's all happening between the coil and capacitor, and not in the AC power lines. So, if your appliance contains a large coil induction motor, you can make the motor behave as a pure resistor, and reduce the current in the power lines by connecting the right value of capacitance across the motor coil. Why is reactive power so confusing? Well, the math is daunting if not entirely obscure. And the concept of "imaginary power" puts many people off. But this is not the only problem. Unfortunately most of us are taught in grade school that an electric current is a flow of energy, and that energy flows back and forth in AC power lines. This is completely wrong. In fact the energy flows constantly forward, going from source to load. It's only the charges of the metal wires which flow back and forth.

## **2. GENERATION AND ABSORPTION OF REACTIVE POWER**

### **Synchronous Generators:**

Synchronous machines can be made to generate or absorb reactive power depending upon the excitation (a form of generator control) applied. The ability to supply reactive power is determined by the short circuit ratio.

### **Synchronous Compensators:**

Certain smaller generators, once run up to speed and synchronized to the system, can be declutched from their turbine and provide reactive power without producing real power.

### **Capacitive and Inductive Compensators:**

These are devices that can be connected to the system to adjust voltage levels .A capacitive compensator produces an electric field thereby generating reactive power An inductive compensator produces a magnetic field to absorb reactive power. Compensation devices are available as either capacitive or inductive alone or as a hybrid to provide both generation and absorption of reactive power.

1. Overhead lines and underground cables, when operating at the normal system voltage, both produce strong electric fields and so generate reactive power.
2. When current flows through a line or cable it produces a magnetic field which absorbs reactive power.
3. A lightly loaded overhead line is a net generator of reactive power while a heavily loaded line is a net absorber of reactive power.
4. In the case of cables designed for use at 275 or 400kV the reactive power generated by the electric field is always greater than the reactive power absorbed by the magnetic field and so cables are always net generators of reactive power.
5. Transformers always absorb reactive power.

---

## **4.METHODS OF VOLTAGE CONTROL**

### **Reactors:**

Inductive reactors absorb reactive power and may be used in circuits, series or shunt connected, while series connected reactors are used to limit fault currents, shunt reactors are used for var control. Reactors installed at line ends and intermediate substations can compensate up to 70% of charging power while the remaining 30% power at no-load can be provided by the under excited operation of the generator. With increase in load, generator

excitation may be increased with reactors gradually cut-out. Figure shows some typical shunt reactor arrangements.

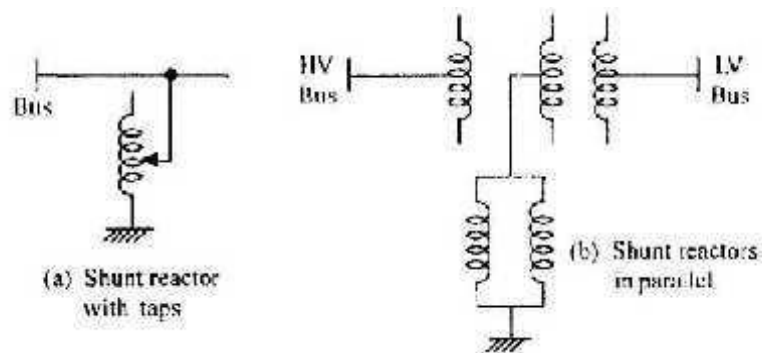

**Figure - Typical Shunt Reactor**

### Shunt Capacitors:

Capacitors produce var and may be connected in series or shunt in the system. Series capacitors compensate the line reactance in long overhead lines and thus improve the stability limit. However, they give rise to additional problems like high voltage transients, sub-synchronous resonance, etc. Shunt capacitors are used for reactive compensation. Simplicity and low cost are the chief considerations for using shunt capacitor. Further, for expanding systems additions can be made. Fig. shows the connected of shunt capacitors through the tertiary of a transformer.

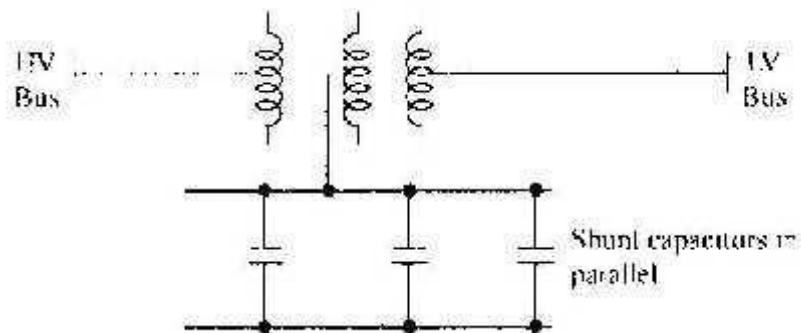

**Shunt capacitor**

### Series capacitors:

Here the capacitors are connected in series with the line. The main aim is to reduce the inductive reactance between supply point and the load. The major disadvantage of the method is, whenever short circuit current flows through the capacitor, protective devices like spark gaps and non linear resistors are to be incorporated. Phasor diagram for a line with series capacitor is shown in the figure (b).



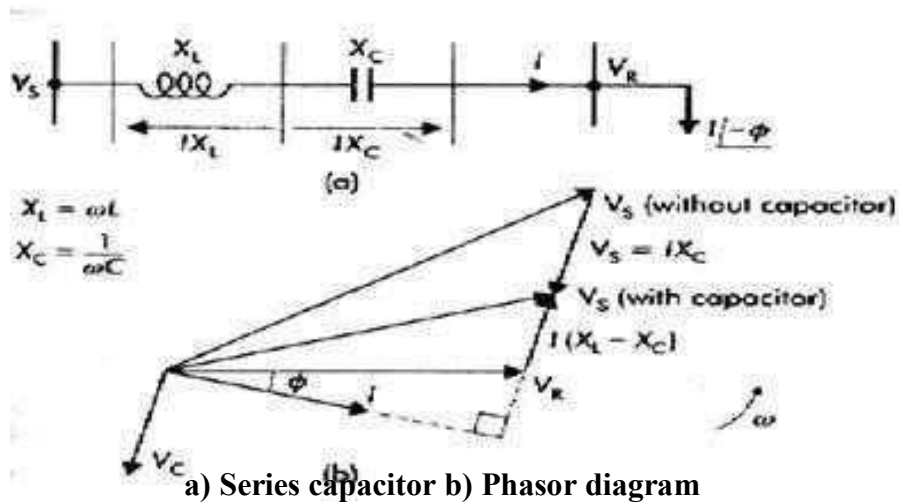

### Relative merits between shunt and series capacitors.

1. If the load var requirement is small, series capacitors are of little help.
2. If the voltage drop is the limiting factor, series capacitors are effective; also to some extent the voltage fluctuations can be evened.
3. If the total line reactance is high, series capacitors are very effective and stability is improved.
4. With series capacitors the reduction in line current is small, hence if the thermal considerations limits the current, little advantage is from this, so shunt compensation is to be used.

### Synchronous compensators:

A synchronous compensator is a synchronous motor running without a mechanical load and depending on the excitation level; it can either absorb or generate reactive power. When used with a voltage regulator the compensator can automatically run overexcited at times of high loads and under excited at light loads. A typical connection of a compensator is shown in the figure along with the associated voltage – var output characteristics.

A great advantage of the method is the flexible operation for all load conditions. Being a rotating machine, its stored energy is useful for riding through transient disturbances, including voltage drops.

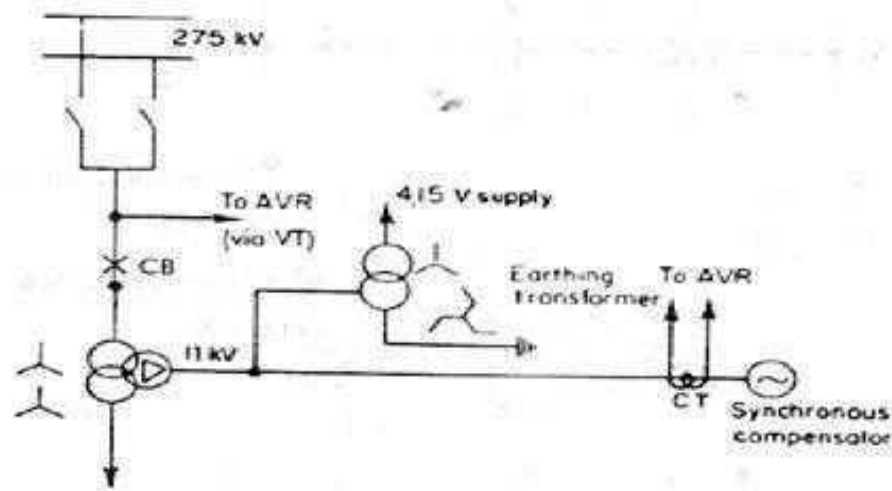

**Synchronous Compensator**

Even though the capacitors and reactors in are shown in figure connected to the low voltage side of a down transformer, the capacitor banks may be distributed between high and low voltage buses. The capacitor bank often includes, in part, harmonic filters which prevent the harmonic currents from flowing in the transformer and the high voltage system. Filters for the 5th and 7th harmonics are generally provided. The thyristor controlled reactor (TCR) is operated on the low voltage bus. In another form of the compensator illustrated in Figure the reactor compensator is connected to the secondary of a transformer.

With this transformer, the reactive power can be adjusted to anywhere between 10% to the rated value. With a capacitor bank provided with steps, a full control range from capacitive to inductive power can be obtained. The reactor's transformer is directly connected to the line, so that no circuit breaker is needed.

### 3. Static VAR compensators:

In Recent years reactive compensation of charging power is made feasible with the application of 3-phase, thyristor, and power controller circuits with automatic control functions.

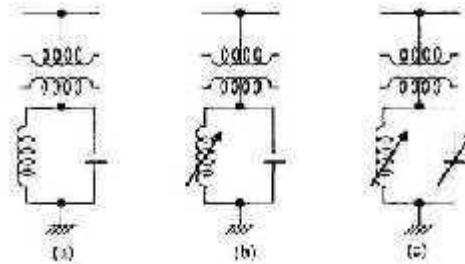

#### Static VAR Compensator

The term static var compensator is applied to a number of static var compensation devices for use in shunt reactive control. These devices consist of shunt connected, static reactive element (linear or non linear reactors and capacitors) configured into a var compensating system. Some possible configurations are shown in above Figure. Even though the capacitors and reactors in are shown in figure connected to the low voltage side of a down transformer, the capacitor banks may be distributed between high and low voltage buses. The capacitor bank often includes, in part, harmonic filters which prevent the harmonic currents from flowing in the transformer and the high voltage system. Filters for the 5th and 7th harmonics are generally provided. The thyristor controlled reactor (TCR) is operated on the low voltage bus. In another form of the compensator illustrated in Figure the reactor compensator is connected to the secondary of a transformer.

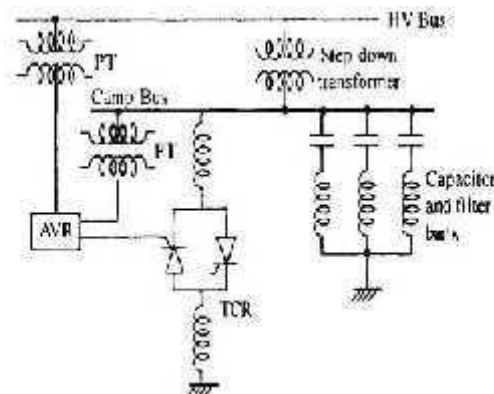

#### Reactor Compensator

The primary winding is star connected with neutral grounded, suitable to the thyristor network. The secondary reactor is normally nonexistent, as it is more economical to design the reactor transformer with 200% leakage impedance between primary and secondary windings. The delta connected tertiary winding will effectively compensate the triple harmonics. The capacitor bank is normally subdivided and connected to the substation bus bar via one circuit breaker per sub bank. The regulator generates firing pulses for the thyristor network in such a way that the reactive power required to meet the control objective at the primary side of the compensator is obtained. The reactor transformer has a practically linear characteristic from no load to full load condition. Thus, even under all stained over voltages; hardly any harmonic content is generated due to saturation. The transformer core has non ferromagnetic .Gaps to the required linearity.

The following requirements are to be borne in mind while designing a compensator.

1. Reaction should be possible, fast or slow, whenever demanded. No switching of capacitor should take place at that time to avoid additional transients in the system. Commutation from capacitor to reactor and vice versa should be fast.
2. No switching of the capacitors at the high voltage bus bar, so that no higher frequency Transients is produced at EHV level.
3. Elimination of higher harmonics on the secondary side and blocking them from entering the system.

In a three phase system the thyristor controlled inductors are normally delta connected as shown in Figure to compensate unbalanced loads and the capacitors may be star or delta connected

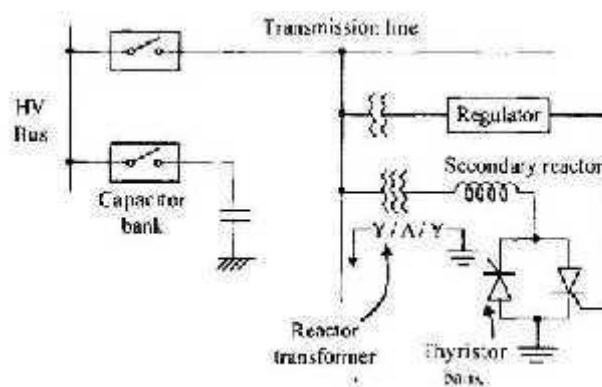

### Unbalanced loads

In the thyristor controlled reactor, the inductive reactance is controlled by the thyristors. For a limited range of operation the relationship between the inductive current  $i_L$  and the applied voltage  $V$  is represented in Figure. As the inductance is varied, the susceptance varies over a range within the limits  $B_{Lmin}$  and  $B_{Lmax}$  (corresponding to  $X_{Lmax}$  and  $X_{Lmin}$ ) while the voltage Changes by  $v$  volts.

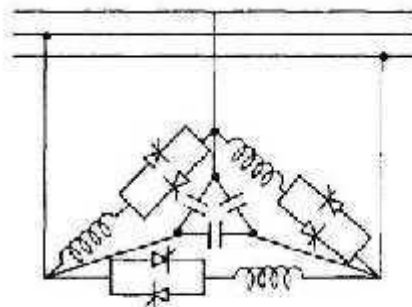

Fixed capacitor, thyristor controlled inductor type var compensator

### Unbalanced loads

The current flowing in the inductance would be different in each half cycle, varying with the conduction angle such that each successive half cycle is a smaller segment of a sine wave. The fundamental component of inductor current is then reduced to each case. Quick control can be exercised within one half cycles, just by giving a proper step input to the firing angle control Static var compensators when installed reduce the voltage swings at the rolling mill and power system buses in drive system applications. They compensate for the average reactive power requirements and improve power factor.

Electric arc furnaces impose extremely difficult service requirements on electrical power systems since the changes in arc furnace load impedance are rapid. Random and non symmetrical. The three phases of a static var compensator can be located independently so that it compensates for the unbalanced reactive load of the furnace and the thyristor controller will respond quickly in order to minimize the voltage fluctuations or voltage flicker seen by the system.

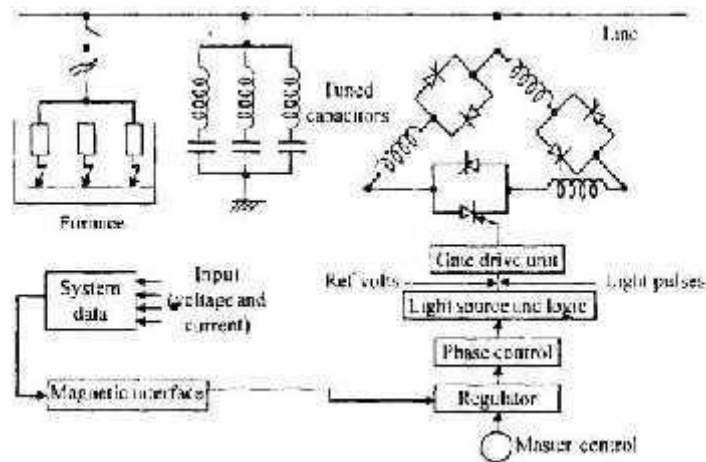

### Application of the static VAR compensator

Thus, the furnace characteristics are made more acceptable to the power system by the static var compensator. Above figure shows the application of the static var compensator to an arc furnace installation for reactive power compensation at the HV bus level.

## TYPES OF SVC

1. Variable impedance type
2. Current source type
3. Voltage source type

The followings are the basic types of reactive power control elements which makes all or parts of SVC

Saturated reactor

1. Thyristor controlled Reactor
2. Thyristor switched capacitor
3. Thyristor Switched Reactor
4. Thyristor controlled Transformer

## APPLICATION OF STATIC VAR COMPENSATOR

- Connected to the power system, to regulate the transmission voltage ("Transmission SVC")
- Connected near large industrial loads, to improve power quality ("Industrial SVC")

## EXCITATION SYSTEMS REQUIREMENTS

1. Meet specified response criteria.
2. Provide limiting and protective functions are required to prevent damage to itself, the generator, and other equipment.
3. Meet specified requirements for operating flexibility
4. Meet the desired reliability and availability, by incorporating the necessary level of redundancy and internal fault detection and isolation capability.

## ELEMENTS OF EXCITATION SYSTEM

**Exciter:** provides dc power to the synchronous machine field winding constituting the power stage of the excitation system.

**Regulator:** Process and amplifies input control signals to a level and form appropriate for control of the exciter. This includes both regulating and excitation system stabilizing function.

**Terminal voltage transducer and load compensator:** Senses generator terminal voltage, rectifier and filters it to dc quantity, and compares it with a reference which represents the desired terminal voltage.

**Power system stabilizer:** provides an additional input signal to the regulator to damp power system oscillation.

**Limiters and protective circuits:** These include a wide array of control and protective function which ensure that the capability limits of the exciter and synchronous generator are not exceeded.

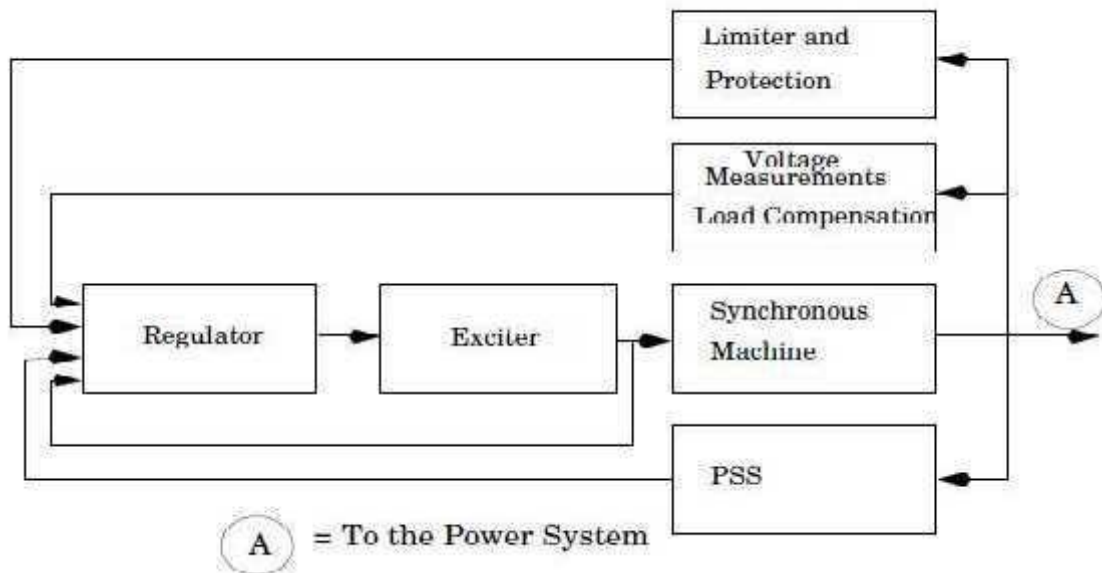

**Schematic picture of a synchronous machine with excitation system with several control, protection, and supervisory functions.**

## **TYPES OF EXCITATION SYSTEM**

Today, a large number of different types of exciter systems are used. Three main types can be distinguished:

- **DC excitation system**, where the exciter is a DC generator, often on the same axis as the rotor of the synchronous machine.
- **AC excitation system**, where the exciter is an AC machine with rectifier.
- **Static excitation system**, where the exciting current is fed from a controlled rectifier that gets its power either directly from the generator terminals or from the power plant's auxiliary power system, normally containing batteries. In the latter case, the synchronous machine can be started against an unenergised net, "black start". The batteries are usually charged from the net.

### **Block Schematic of Excitation Control:**

A typical excitation control system is shown in Fig. The terminal voltage of the alternator is sampled, rectified and compared with a reference voltage; the difference is amplified and fed back to the exciter field winding to change the excitation current.

Block Diagram of excitation system:

## Block Diagram of Excitation System

### Static Excitation System:

In the static excitation system, the generator field is fed from a thyristor network shown in Fig. It is just sufficient to adjust the thyristor firing angle to vary the excitation level. A major advantage of such a system is that, when required the field voltage can be varied through a full range of positive to negative values very rapidly with the ultimate benefit of generator Voltage regulation during transient disturbances. The thyristor network consists of either 3-phase fully controlled or semi controlled bridge rectifiers. Field suppression resistor dissipates Energy in the field circuit while the field breaker ensures field isolation during generator faults.

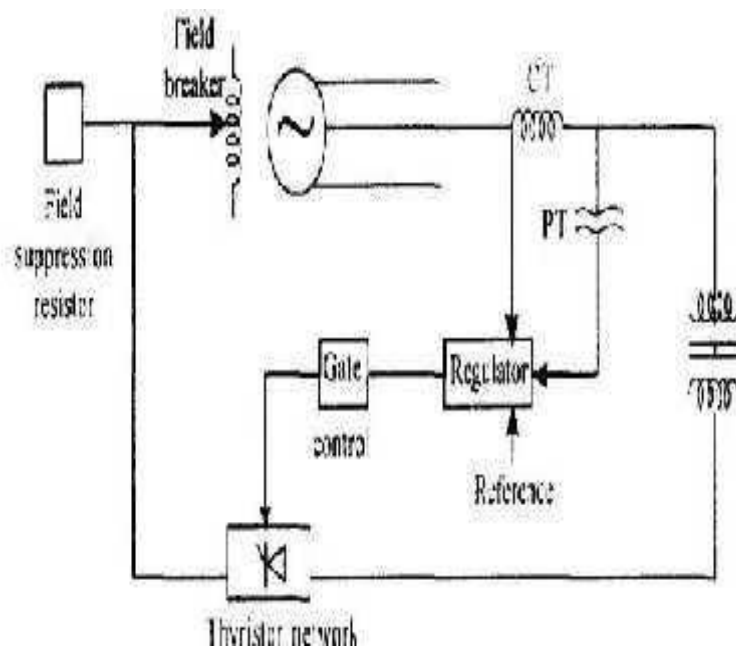

Static Excitation System



**Brushless Excitation Scheme:**

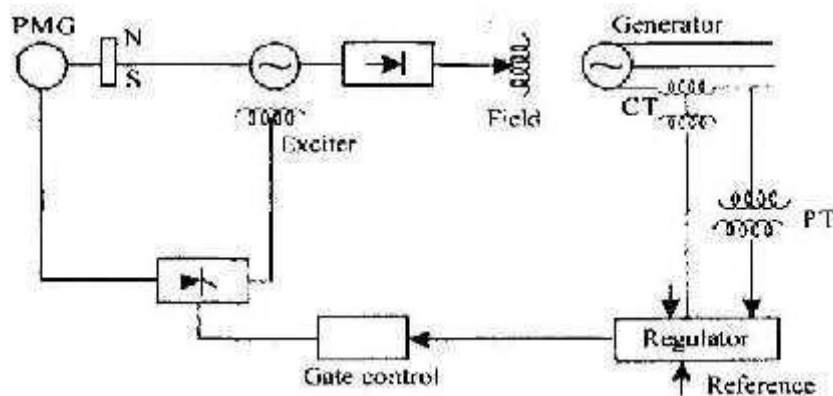

**Brushless Excitation Scheme:**

In the brushless excitation system of an alternator with rotating armature and stationary field is employed as the main exciter. Direct voltage for the generator excitation is obtained by rectification through a rotating, semiconductor diode network which is mounted on the generator shaft itself. Thus, the excited armature, the diode network and the generator field are rigidly connected in series. The advantage of this method of excitation is that the moving contacts such as slip rings and brushes are completely eliminated thus offering smooth and maintenance-free operation.

A permanent-magnet generator serves as the power source for the exciter field. The output of the permanent magnet generator is rectified with thyristor network and is applied to the exciter field. The voltage regulator measures the output or terminal voltage, compares it with a set reference and utilizes the error signal, if any, to control the gate pulses of the thyristor network.

**AC Excitation system:**

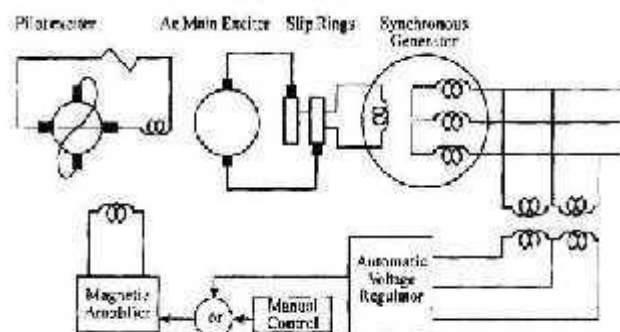

**Ac Excitation System**

Where  $V_1$  is the terminal voltage and  $V_{ref}$  is the reference voltage.

**Exciter ceiling voltage:** It is defined as the maximum voltage that may be attained by an exciter with specified conditions of load.

**Exciter response:** It is the rate of increase or decrease of the exciter voltage. When a change in this voltage is de the response curve shown in Figure.

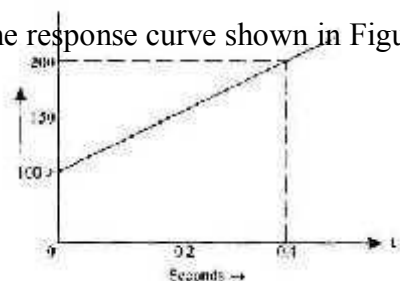

### Exciter Response

**Exciter builds up:** The exciter build up depends upon the field resistance and the charging of its value by cutting or adding. The greatest possible control effort is the complete shorting of the field rheostat when maximum current value is reached in the field circuit. This can be done by closing the contactor.

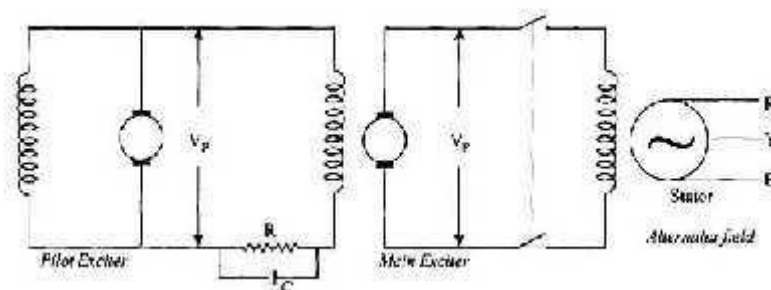

### AC excitation operations

When the exciter is operated at rated speed at no load, the record of voltage as function of time with a step change that drives the exciter to its ceiling voltage is called the exciter build up curve. Such a response curve is show in Figure.4.1

<b>Response ratio</b>	<b>Conventional Exciter</b>	<b>SCR exciter</b>
0.5	1.25-1.35	1.2
1.0	1.4-1.5	1.2-1.25
1.5	1.55-1.65	1.3-1.4
2.0	1.7-1.8	1.45-1.55
4.0		2.0-2.1

**Comparison between Exciters**

In general the present day practice is to use 125V excitation up to 100MVA units and 250V systems up to 100MVA units. Units generating power beyond 100MVA have excitation system voltages variedly. Some use 350V and 375V system while some go up to 500V excitation system.

### **DC Excitation System**

The excitation system of this category utilize dc generator as source of excitation power and provide current to the rotor of the synchronous machine through slip ring. The exciter may be driven by a motor or the shaft of the generator. It may be either self excited or separately excited. When separately excited, the exciter field is supplied by a pivot exciter comprising a permanent magnet generator. Below figure a simplified schematic representation of a typical dc excitation system. It consists of a dc commutator exciter which supplies direct current to the main generator field through slip ring.

## **DC Excitation System**

Dc machine having two sets of brush 90 electrical degree apart, one set on its direct (d) axis and the other set on its quadrature (q) axis. The control field winding is located on the d axis. A compensating winding in series with the d axis armature current, thereby cancelling negative feedback of the armature reaction. The brushes on the q axis are shorted, and very little control field power is required to produce a large current in the q axis armature. The q axis current is supplied mechanically by the motor.

### **RECENT DEVELOPMENT AND FUTURE TRENDS**

The advances in excitation system over the last 20 years have been influenced by development in solid state electronics. Development in analogue integrated circuitry has made it possible to easily implemented complex control strategies.

The latest development in excitation system has been the introduction of digital technology. Thyristor continue to be used for the power stage. The control, protection, and logic function have been implemented digitally, essentially duplicating the function previously provided by analog circuitry.

### **MODELING OF EXCITATION SYSTEM**

Mathematical model of excitation system are essential for the assessment of desired performance requirement, for the design and coordination of supplementary control and protective circuits, and for system stability studies related to the planning and purpose of study.

---

## Generator Voltage Control

The voltage control system is also called as excitation control system or automatic voltage regulator (AVR).

For the alternators, the excitation is provided by a device (another machine or a static device) called exciter. For a large alternator the exciter may be required to supply a field current of as large as 6500A at 500V and hence the exciter is a fairly large machine. Depending on the way the dc supply is given to the field winding of the alternator (which is on the rotor), the exciters are classified as: i) DC Exciters; ii) AC Exciters; and iii) Static Exciters. Accordingly, several standard block diagrams are developed by the IEEE working group to represent the excitation system.

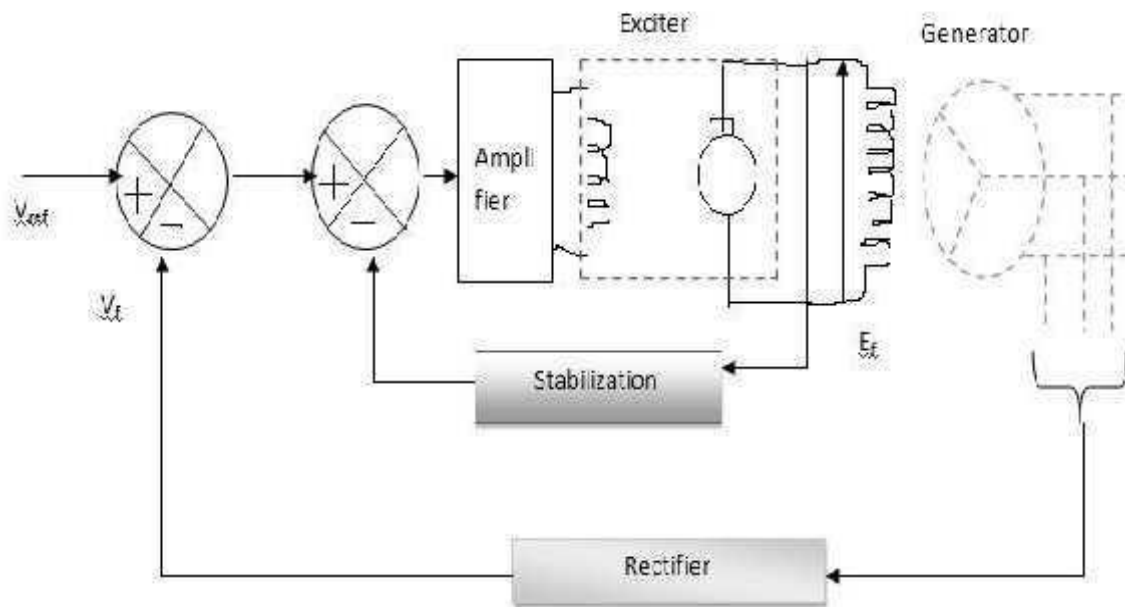

**A schematic of Excitation (Voltage) Control System.**

A simplified block diagram of the generator voltage control system. The generator terminal voltage  $V_t$  is compared with a voltage reference  $V_{ref}$  to obtain a voltage error signal  $\Delta V$ . This signal is applied to the voltage regulator shown as a block with transfer function  $K_A / (1 + T_A s)$ . The output of the regulator is then applied to exciter shown with a block of transfer function  $K_e / (1 + T_e s)$ . The output of the exciter  $E_{fd}$  is then applied to the field winding which adjusts the generator terminal voltage. The generator field can be represented by a block with a transfer function  $K_F / (1 + sTF)$ . The total transfer function

The stabilizing compensator shown in the diagram is used to improve the dynamic response of the exciter. The input to this block is the exciter voltage and the output is a stabilizing feedback signal to reduce the excessive overshoot.

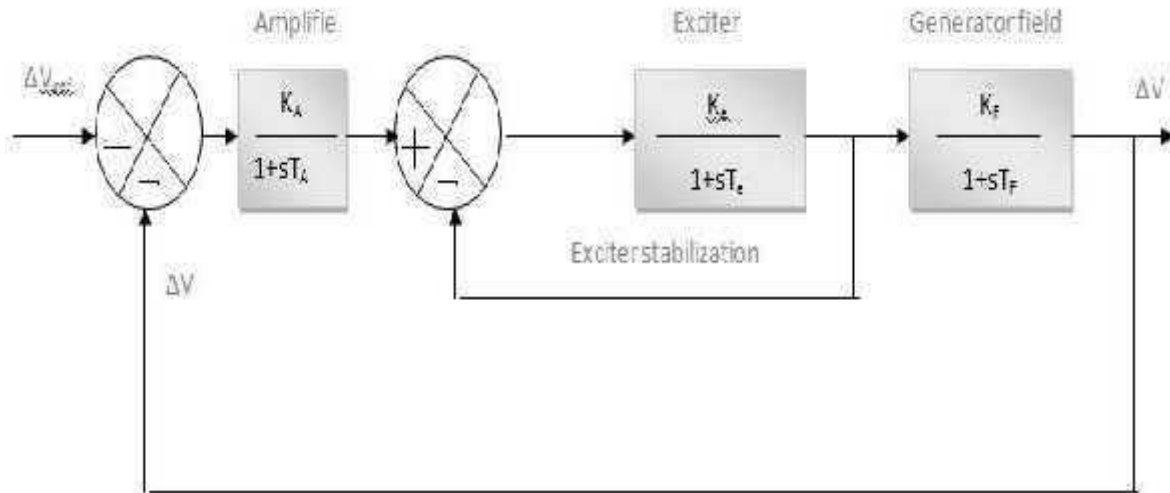

**A simplified block diagram of Voltage (Excitation) Control System.**

### Performance of AVR loop

The purpose of the AVR loop is to maintain the generator terminal voltage with in acceptable values. A static accuracy limit in percentage is specified for the AVR, so that the terminal voltage is maintained within that value. For example, if the accuracy limit is 4%, then the terminal voltage must be maintained within 4% of the base voltage.

### STEADY STATE PERFORMANCE EVALUATION

The control loop must regulate the output voltage  $V_t$  so that the error is made equal to zero. It is also imperative that the response must be reasonably fast, yet not cause any instability problem.

The performance of the AVR loop is measured by its ability to regulate the terminal voltage of the generator within prescribed static accuracy limit with an acceptable speed of response. Suppose the static accuracy limit is denoted by  $A_c$  in

percentage with reference to the nominal value. The error voltage is to be less than  $(AC/100)\Delta|V|_{ref}$ .

From the block diagram, for a steady state error voltage  $\Delta e$ ;

$$\Delta e = \Delta [V]_{ref} - \Delta [V]_t < \frac{AC}{100} \Delta [V]_{ref}$$

$$\begin{aligned} \Delta e &= \Delta [V]_{ref} - \Delta [V]_t = \Delta [V]_{ref} - \frac{G(s)}{1+G(s)} \Delta [V]_{ref} \\ &= 1 - \frac{G(s)}{1+G(s)} \Delta [V]_{ref} \end{aligned}$$

For constraint input condition (s=0)

$$\begin{aligned} \Delta e &= 1 - \frac{G(0)}{1+G(0)} \Delta [V]_{ref} \\ &= 1 - \frac{1}{1+K} \Delta [V]_{ref} \\ &= \frac{1}{1+K} \Delta [V]_{ref} \end{aligned}$$

$K = G(0)$  is the open loop gain of the AVR. Hence

$$\frac{1}{1+K} \Delta [V]_{ref} < \frac{AC}{100} \Delta [V]_{ref}$$

The steady state voltage error  $\Delta e_{ss}$  is given by

$$\begin{aligned} \Delta e_{ss} &= \Delta |V|_{ref}^n - \Delta V_{ss} \\ &= \Delta |V|_{ref}^n - \frac{G(0)}{1+G(0)} \Delta |V|_{ref}^n \end{aligned}$$

where  $G(0)$  is the value of  $G(s)$  as  $s \rightarrow 0$  (i.e.) the steady state value

$$\begin{aligned} &= \frac{1+G(0)-G(0)}{1+G(0)} \Delta |V|_{ref}^n \\ &= \frac{1}{1+G(0)} \Delta |V|_{ref}^n \\ G(0) &= \frac{K_A}{(1+0)} \frac{K_e}{(1+0)} \frac{K_{gr}}{(1+0)} = K \\ \Delta e_{ss} &= \frac{1}{1+K} \end{aligned}$$

Larger the overall gain of the forward block gain  $K$  smaller is the steady state error. But too large a gain  $K$  can cause instability.

## DYNAMIC RESPONSE OF VOLTAGE REGULATION CONTROL:

Consider

$$\Delta V(t) = \mathcal{L}^{-1} \left[ \Delta V_{ref}(S) \frac{G(S)}{1 - G(S)} \right]$$

The response depends upon the roots of the characteristic eqn.  $1 + G(S) = 0$ .

As there are three time constants, we may write the three roots as  $S_1$ ,  $S_2$  and  $S_3$ . A typical root locus plot is shown in Figure

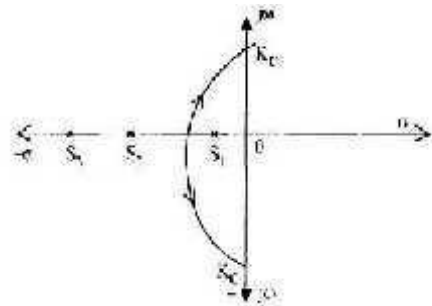

Root locus

From the plot, it can be observed that at gain higher than  $K_c$  the control loop becomes unstable.



**UNIT -IV**

**ECONOMIC OPERATION OF POWER SYSTEM**

## **ECONOMIC DISPATCH**

### **Economic Operation of Power Systems**

One of the earliest applications of on-line centralized control was to provide a central facility, to operate economically, several generating plants supplying the loads of the system. Modern integrated systems have different types of generating plants, such as coal fired thermal plants, hydel plants, nuclear plants, oil and natural gas units etc. The capital investment, operation and maintenance costs are different for different types of plants.

**The operation economics can again be subdivided into two parts.**

- i) Problem of *economic dispatch*, which deals with determining the power output of each plant to meet the specified load, such that the overall fuel cost is minimized.
- ii) Problem of *optimal power flow*, which deals with minimum – loss delivery, where in the power flow, is optimized to minimize losses in the system. In this chapter we consider the problem of economic dispatch.

During operation of the plant, a generator may be in one of the following states:

- i) Base supply without regulation: the output is a constant.
- ii) Base supply with regulation: output power is regulated based on system load.
- iii) Automatic non-economic regulation: output level changes around a base setting as area control error changes.
- iv) Automatic economic regulation: output level is adjusted, with the area load and area control error, while tracking an economic setting.

Regardless of the units operating state, it has a contribution to the economic operation, even though its output is changed for different reasons. The factors influencing the cost of generation are the generator efficiency, fuel cost and transmission losses. The most efficient generator may not give minimum cost, since it may be located in a place where fuel cost is high. Further, if the plant is located far from the load centers, transmission losses may be high and running the plant may become uneconomical. The economic dispatch problem basically determines the generation of different plants to minimize total operating cost.

Modern generating plants like nuclear plants, geo-thermal plants etc, may require capital Investment of millions of rupees. The economic dispatch is however determined in terms of fuel cost per unit power generated and does not include capital investment, maintenance, depreciation, start-up and

**Performance Curves**

**Input-Output Curve**

This is the fundame thermal units (Btu) per ho

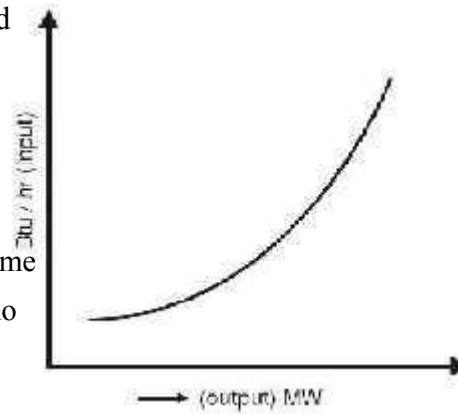

s a plot of the input in British nt in MW as shown in Fig 2.1

**Input – output curve**

**Heat Rate Curve**

The heat rate is the ratio of fuel input in Btu to energy output in KWh. It is the slope of the input – output curve at any point. The reciprocal of heat – rate is called fuel –efficiency. The heat rate curve is a plot of heat rate versus output in MW.

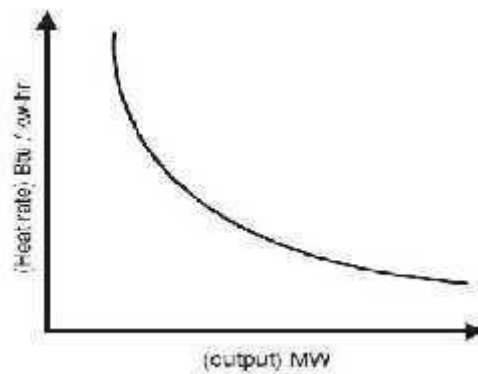

**Heat rate curve.**

**Incremental Fuel Rate Curve**

The incremental fuel rate is equal to a small change in input divided by the corresponding change in output.

$$\text{Incremental fuel rate} = \frac{\Delta \text{Input}}{\Delta \text{Output}}$$

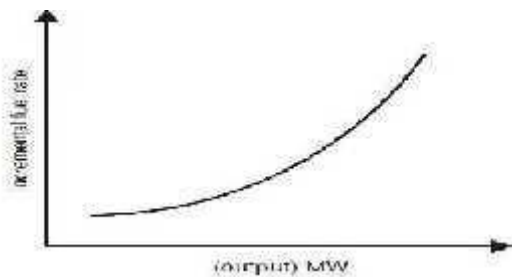

**INCREMENTAL COST**

The incremental cost is the product of incremental fuel rate and fuel cost (Rs / Btu or \$ /Btu). The curve is shown in Fig. 4. The unit of the incremental fuel cost is Rs / MWh or \$ /MWh.

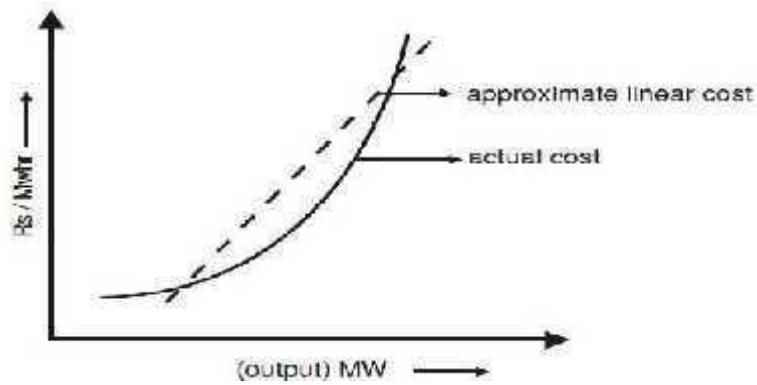

**Incremental cost curve**

In general, the fuel cost  $F_i$  for a plant, is approximated as a quadratic function of the generated output  $P_{Gi}$ .

$$F_i = a_i + b_i P_{Gi} + c_i P_{Gi}^2 \text{ Rs / h} \text{ ----- (4)}$$

The incremental fuel cost is given by

$$\text{-----Rs / MWh ----- (5)}$$

The incremental fuel cost is a measure of how costly it will be produce an increment of power. The incremental production cost, is made up of incremental fuel cost plus the incremental cost of labour, water, maintenance etc. which can be taken to be some percentage of the incremental fuel cost, instead of resorting to a rigorous mathematical model. The cost curve can be approximated by a linear curve. While there is negligible operating cost for a hydel plant, there is a limitation on the power output possible. In any plant, all units normally operate between  $P_{Gmin}$ , the minimum loading limit, below which it is technically infeasible to operate a unit and  $P_{Gmax}$ , which is the maximum output limit.

**Solution Methods:**

1. Lagrange Multiplier method
2. Lamda iteration method
3. Gradient method
4. Dynamic programming
5. Evolutionary Computation techniques

**The Economic Dispatch Problem without Loss.**

This system consists of  $N$  thermal-generating units connected to a single bus-bar serving a received electrical load  $P_{load}$  input to each unit, shown as  $F_i$  represents the cost rate of the unit. The output of each unit,  $P_i$ , is the electrical power generated by that particular unit. The total cost rate of this system is, of course, the sum of the costs of each of the individual units. The essential constraint on the operation of this system is that the sum of the output powers must equal the load demand. Mathematically speaking, the problem may be stated very concisely. That is, an objective function,  $F_T$ , is equal to the total cost for supplying the indicated load. The problem is to minimize  $F_T$  subject to the constraint that the sum of the powers generated must equal the received load. Note that any transmission losses are neglected and any operating limits are not explicitly stated when formulating this problem. That is,

$$\begin{aligned}
 F_T &= F_1 + F_2 + F_3 + \dots + F_N \\
 &= \sum_{i=1}^N F_i(P_i) \\
 \phi &= 0 = P_{load} - \sum_{i=1}^N P_i
 \end{aligned}
 \tag{6}$$

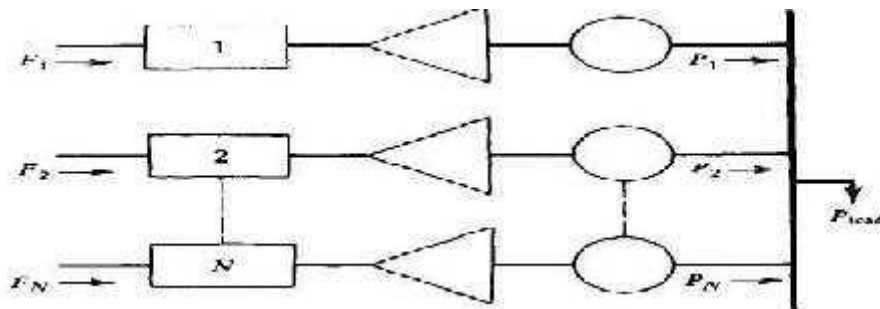

**$N$  thermal units committed to serve a load of  $P_{load}$ .**

This is a constrained optimization problem that may be attacked formally using advanced calculus methods that involve the Lagrange function. In order to establish the necessary conditions for an extreme value of the objective function, add the constraint function to the objective function after the constraint function has been multiplied by an undetermined multiplier. This is known as the **Lagrange function** and is shown in Eq(7)

The necessary conditions for an extreme value of the objective function result when we take the first derivative of the Lagrange function with respect to each of the independent variables and set the derivatives equal to zero. In this case, there are  $N+1$  variables, the  $N$  values of power output,  $P_i$ , plus the undetermined Lagrange multiplier,  $\lambda$ . The derivative of the Lagrange function with respect to the undetermined multiplier merely gives back the constraint equation. On the other hand, the  $N$  equations that result when we take the partial derivative of the Lagrange function with respect to the power output values one at a time give the set of equations shown as Eq. 8.

$$\begin{array}{ll} \frac{dF_L}{dP_i} = \lambda & N \text{ equations} \\ P_{i,\min} \leq P_i \leq P_{i,\max} & 2N \text{ inequalities} \\ \sum_{i=1}^N P_i = P_{\text{load}} & 1 \text{ constraint} \end{array}$$

When we recognize the inequality constraints, then the necessary conditions may be expanded slightly as shown in the set of equations making up

### **Thermal System Dispatching With Network Losses Considered**

symbolically an all-thermal power generation system connected to an equivalent load bus through a transmission network. The economic dispatching problem associated with this particular configuration is slightly more complicated to set up than the previous case. This is because the constraint equation is now one that must include the network losses. The

objective function,  $F_T$ , is the same as that defined for Eq.10

$$P_{\text{load}} + P_{\text{loss}} - \sum_{i=1}^N P_i = \phi = 0 \quad \text{----- (10)}$$

The same procedure is followed in the formal sense to establish the necessary conditions for a minimum-cost operating solution, The Lagrange function is shown in Eq.11. In taking the derivative of the Lagrange function with respect to each of the individual power outputs,  $P_i$ , it must be recognized that the loss in the transmission network,  $P_{\text{LOSS}}$  is a function of the network impedances and the currents flowing in the network. For our purposes, the currents will be considered only as a function of the independent variables  $P_i$  and the load  $P_{\text{load}}$  taking the derivative of the Lagrange function with respect to any one of the  $N$  values of  $P_i$  results in Eq. 11. collectively as the *coordination equations*.

It is much more difficult to solve this set of equations than the previous set with no losses since this second set involves the computation of the network loss in order to establish the validity of the solution in satisfying the constraint equation. There have been two general approaches to the solution of this problem. The first is the development of a mathematical expression for the losses in the network solely as a function of the power output of each of the units. This is the loss-formula method discussed at some length in Kirchmayer's *Economic Operation of Power Systems*. The other basic approach to the solution of this problem is to incorporate the power flow equations as essential constraints in the formal establishment of the optimization problem. This general approach is known as the optimal powerflow.

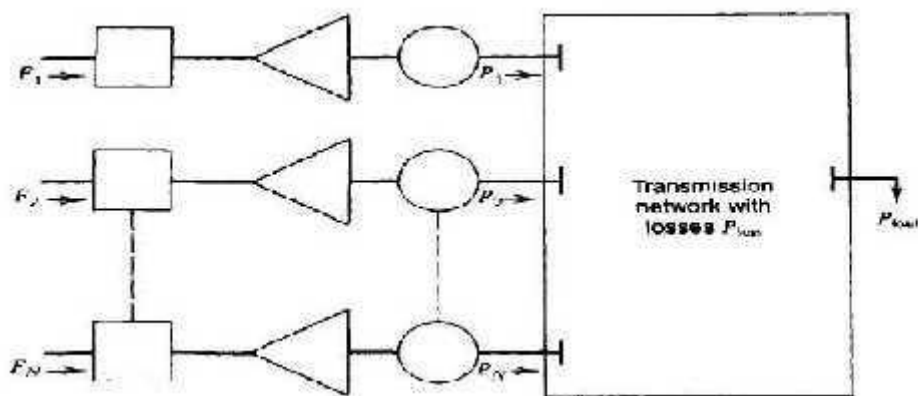

**N thermal units serving load through transmission network**

### The Lambda-Iteration Method

block diagram of the lambda-iteration method of solution for the all-thermal, dispatching problem-neglecting losses. We can approach the solution to this problem by considering a graphical technique for solving the problem and then extending this into the area of computer algorithms. Suppose we have a three-machine system and wish to find the optimum economic operating point. One approach would be to plot the incremental cost characteristics for each of these three units on the same graph,

In order to establish the operating points of each of these three units such that we have minimum cost and at the same time satisfy the specified demand, we could use this sketch

and a ruler to find the solution. That is, we could assume an incremental cost rate ( $\lambda$ ) and find the power outputs of each of the three units for this value of incremental cost. the three units for this value of incremental cost. Of course, our first estimate will be incorrect. If we have assumed the value of incremental cost such that the total power output is too low, we must increase the  $\lambda$  value and try another solution. With two solutions, we can extrapolate (or interpolate) the two solutions to get closer to the desired value of total received power. By keeping track of the total demand versus the incremental cost, we can rapidly find the desired operating point. If we wished, we could manufacture a whole series of tables that would show the total power supplied for different incremental cost levels and combinations of units. That is, we will now establish a set of logical rules that would enable us to accomplish the same objective as we have just done with ruler and graph paper. The actual details of how the power output is established as a function of the incremental cost rate are of very little importance.

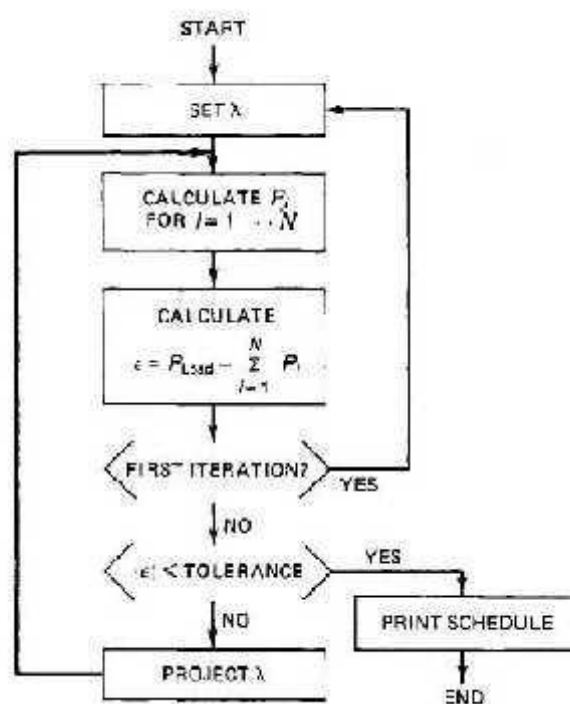

**Lambda-iteration method**

We could, for example, store tables of data within the computer and interpolate between the stored power points to find exact power output for a specified value of incremental cost rate. Another approach would be to develop an analytical function for the power output as a function of the incremental cost rate, store this function (or its coefficients) in the computer, and use this to establish the output of each of the individual units.



This procedure is an iterative type of computation, and we must establish stopping rules. Two general forms of stopping rules seem appropriate for this application. The lambda-iteration procedure converges very rapidly for this particular type of optimization problem. The actual computational procedure is slightly more complex than that indicated, since it is necessary to observe the operating limits on each of the units during the course of the computation. The well-known Newton-Raphson method may be used to project the incremental cost value to drive the error between the computed and desired generation to zero.

### Base Point and Participation Factors

This method assumes that the economic dispatch problem has to be solved repeatedly by moving the generators from one economically optimum schedule to another as the load changes by a reasonably small amount. We start from a given schedule—the *base point*. Next, the scheduler assumes a load change and investigates how much each generating unit needs to be moved (i.e., “participate” in the load change) in order that the new load be served at the most economic operating point. Assume that both the first and second derivatives in the cost versus power output function are available (i.e., both  $F_i$  and  $F_i'$  exist). The incremental cost

at  $P_i^0$  for a small change in power output on this single unit,

$$\Delta \lambda_i = \Delta \lambda \cong F_i''(P_i^0) \Delta P_i \quad \text{----- (13)}$$

This is true for each of the units on the system, so that

$$\begin{aligned} \Delta P_1 &= \frac{\Delta \lambda}{F_1''} \\ \Delta P_2 &= \frac{\Delta \lambda}{F_2''} \\ &\vdots \\ \Delta P_N &= \frac{\Delta \lambda}{F_N''} \end{aligned} \quad \text{----- (14)}$$

The total change in generation (=change in total system demand) is, of course, the sum of the individual unit changes. Let  $P_D$  be the total demand on the generators (where  $P_{load} + P_{loss}$ ),

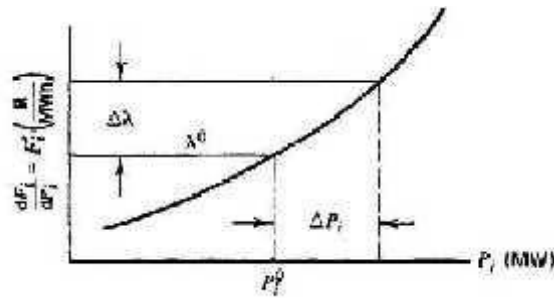

$$\begin{aligned} \Delta P_D &= \Delta P_1 + \Delta P_2 + \dots + \Delta P_N \\ &= \Delta \lambda \sum_i \left( \frac{1}{F_i''} \right) \end{aligned} \quad \text{----- (15)}$$

The earlier equation, 15, can be used to find the **participation factor** for each unit as follows

$$\left( \frac{\Delta P_i}{\Delta P_D} \right) = \frac{(1/F_i'')}{\sum_i \left( \frac{1}{F_i''} \right)} \quad \text{----- (16)}$$

The computer implementation of such a scheme of economic dispatch is straightforward. It might be done by provision of tables of the values of  $FY$  as a function of the load levels and devising a simple scheme to take the existing load plus the projected increase to look up these data and compute the factors. somewhat less elegant scheme to provide participation factors would involve a repeat economic dispatch calculation at. The base-point economic generation values are then subtracted from the new economic generation values and the difference divided to provide the participation factors. This scheme works well in computer implementations where the execution time for the economic dispatch is short and will always give consistent answers when units reach limits, pass through break points on piecewise linear incremental cost functions, or have nonconvex cost curves.

## **UNIT COMMITMENT**

The life style of a modern man follows regular habits and hence the present society also follows regularly repeated cycles or pattern in daily life. Therefore, the consumption of electrical energy also follows a predictable daily, weekly and seasonal pattern. There are periods of high power consumption as well as low power consumption. It is therefore possible to commit the generating units from the available capacity into service to meet the demand. The previous discussions all deal with the computational aspects for allocating load to a plant in the most economical manner. For a given combination of plants the determination of optimal combination of plants for operation at any one time is also desired for carrying out the aforesaid task. The plant commitment and unit ordering schedules extend the period of optimization from a few minutes to several hours. From daily schedules weekly patterns can be developed. Likewise, monthly, seasonal and annual schedules can be prepared taking into consideration the repetitive nature of the load demand and seasonal variations. Unit commitment schedules are thus required for economically committing the units in plants to service with the time at which individual units should be taken out from or returned to service.

### **Constraints in Unit Commitment**

Many constraints can be placed on the unit commitment problem. The list presented here is by no means exhaustive. Each individual power system, power pool, reliability council, and so forth, may impose different rules on the scheduling of units, depending on the generation makeup, load-curve characteristics, and such.

### **Spinning Reserve**

*Spinning reserve* is the term used to describe the total amount of generation available from all units synchronized (i.e., spinning) on the system, minus the present load and losses being supplied. Spinning reserve must be carried so that the loss of one or more units does not cause too far a drop in system frequency. Quite simply, if one unit is lost, there must be ample reserve on the other units to make up for the loss in a specified time period. Spinning reserve must be allocated to obey certain rules, usually set by regional reliability councils (in the United States) that specify how the reserve is to be allocated to various units. Typical rules specify that reserve must be a given

percentage of forecasted peak demand, or that reserve must be capable of making up the loss of the most heavily loaded unit in a given period of time. Others calculate reserve requirements as a function of the probability of not having sufficient generation to meet the load. Not only must the reserve be sufficient to make up for a generation-unit failure, but the reserves must be allocated among fast-responding units and slow-responding units. This allows the automatic generation control system to restore frequency and interchange quickly in the event of a generating-unit outage. Beyond spinning reserve, the unit commitment problem may involve various classes of “scheduled reserves” or “off-line” reserves. These include quick-start diesel or gas-turbine units as well as most hydro-units and pumped-storage hydro-units that can be brought on-line, synchronized, and brought up to full capacity quickly. As such, these units can be “counted” in the overall reserve assessment, as long as their time to come up to full capacity is taken into account. Reserves, finally, must be spread around the power system to avoid transmission system limitations (often called “bottling” of reserves) and to allow various parts of the system to run as “islands,” should they become electrically disconnected.

### **Thermal Unit Constraints**

Thermal units usually require a crew to operate them, especially when turned on and turned off. A thermal unit can undergo only gradual temperature changes, and this translates into a time period of some hours required to bring the unit on-line. As a result of such restrictions in the operation of a thermal plant, various constraints arise, such as:

- 1. Minimum up time:** once the unit is running, it should not be turned off immediately
- 2. Minimum down time:** once the unit is decommitted, there is a minimum time before it can be recommitted.
- 3. Crew constraints:** if a plant consists of two or more units, they cannot both be turned on at the same time since there are not enough crew members to attend both units while starting up. In addition, because the temperature and pressure of the thermal unit must be moved slowly, a certain amount of energy must be expended to bring the unit on-line. This energy does not result in any MW generation from the unit and is brought into the unit commitment problem as a *start-up cost*. The start-up cost can vary from a maximum “cold-start” value to a much smaller value if the unit was only turned off recently and is still relatively close to operating temperature. There are two approaches to treating a thermal unit during its down period. The first allows the unit’s boiler to cool down and then heat back up to operating temperature in time for a scheduled turn on. The second (called *banking*) requires that sufficient energy be input to the boiler to just maintain

operating temperature. The costs for the two can be compared so that, if possible, the best approach (cooling or banking) can be chosen.

$C_f$  = fixed cost (includes crew expense, maintenance expenses) (in R)

$\alpha$  = thermal time constant for the unit

$t$  = time (h) the unit was cooled

Start-up cost when banking =  $C_t \times t$   
 $\times F + C_f$

$C_t$  = cost (MBtu/h) of maintaining unit at operating temperature

Up to a certain number of hours, the cost of banking will be less than the cost of cooling, as is illustrated in Figure 5.3. Finally, the capacity limits of thermal units may change frequently, due to maintenance or unscheduled outages of various equipment in the plant; this must also be taken

### Other Constraints

### Hydro-Constraints

Unit commitment cannot be completely separated from the scheduling of hydro-units. In this text, we will assume that the hydrothermal scheduling (or “coordination”) problem can be separated from the unit commitment problem. We, of course, cannot assert flatly that our treatment in this fashion will always result in an optimal solution.

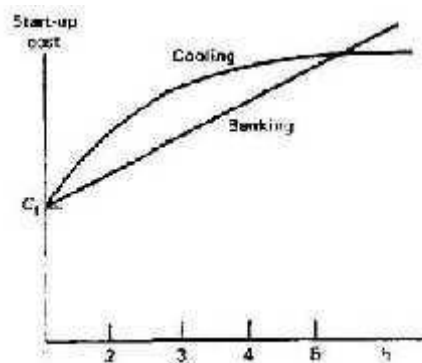

**Hydro-Constraints**

## Must Run

Some units are given a must-run status during certain times of the year for reason of voltage support on the transmission network or for such purposes as supply of steam for uses outside the steam plant itself.

## Fuel Constraints

We will treat the “fuel scheduling” problem system in which some units have limited fuel, or else have constraints that require them to burn a specified amount of fuel in a given time, presents a most challenging unit commitment problem.

## Unit Commitment Solution Methods

The commitment problem can be very difficult. As a theoretical exercise, let us postulate the following situation.

1. We must establish a loading pattern for  $M$  periods.
2. We have  $N$  units to commit and dispatch.
3. The  $M$  load levels and operating limits on the  $N$  units are such that any one unit can supply the individual loads and that any combination of units can also supply the loads.

Next, assume we are going to establish the commitment by enumeration (brute force). The total number of combinations we need to try each hour is,

$$C(N, 1) + C(N, 2) + \dots + C(N, N - 1) + C(N, N) = 2^N - 1 \text{-----(18)}$$

Where  $C(N, j)$  is the combination of  $N$  items taken  $j$  at a time. That is,

$$C(N, j) = \left[ \frac{N!}{(N-j)!j!} \right]$$

$j! = 1 \times 2 \times 3 \times \dots \times j$  -----(19)

These very large numbers are the upper bounds for the number of enumerations required. Fortunately, the constraints on the units and the load-capacity relationships of typical utility systems are such that we do not approach these large numbers. Nevertheless, the real practical barrier in the optimized unit commitment problem is the high dimensionality of the possible solution space.

## The most talked-about techniques for the solution of the unit commitment problem are:

1. Priority-list schemes,
2. Dynamic programming (DP),
3. Lagrange relation (LR).

### Priority-List Method for unit commitment solution:

The simplest unit commitment solution method consists of creating a priority list of units. As a simple shut-down rule or priority-list scheme could be obtained after an exhaustive enumeration of all unit combinations at each load level. The priority list of Example 5B could be obtained in a much simpler manner by noting the full-load average production cost of each unit, where the full-load average production cost is simply the net heat rate at full load multiplied by the fuel cost.

### **Priority List Method:**

Priority list method is the simplest unit commitment solution which consists of creating a priority list of units.

Full load average production cost = Net heat rate at full load X Fuel

cost Assumptions:

1. No load cost is zero
2. Unit input-output characteristics are linear between zero output and full load
3. Start up costs are a fixed amount
4. Ignore minimum up time and minimum down time

Steps to be followed

1. Determine the full load average production cost for each units
2. Form priority order based on average production cost
3. Commit number of units corresponding to the priority order
4. Calculate PG1, PG2 ..... PGN from economic dispatch problem for the feasible combinations only

## Dynamic-Programming Solution

Dynamic programming has many advantages over the enumeration scheme, the chief advantage being a reduction in the dimensionality of the problem. Suppose we have found units in a system and any combination of them could serve the (single) load.

There would be

a maximum of  $2^4 - 1 = 15$  combinations to test. However, if a strict priority order is imposed, there are only four combinations to try:

Priority 1 unit

Priority 1 unit +  
Priority 2 unit

Priority 1 unit + Priority 2 unit +  
Priority 3 unit

Priority 1 unit + Priority 2 unit + Priority 3 unit +  
Priority 4 unit

The imposition of a priority list arranged in order of the full-load average cost rate would result in a theoretically correct dispatch and commitment only if:

1. No load costs are zero.
2. Unit input-output characteristics are linear between zero output and full load.
3. There are no other restrictions.
4. Start-up costs are a fixed amount.

In the dynamic-programming approach that follows, we assume that:

1. A *state* consists of an array of units with specified units operating and
2. The start-up cost of a unit is independent of the time it has been off-line
3. There are no costs for shutting down a unit.
4. There is a strict priority order, and in each interval a specified minimum the rest off-line. (i.e., it is a fixed amount). amount of capacity must be operating.

A feasible state is one in which the committed units can supply the required load and that meets the minimum amount of capacity each period.



## Forward DP Approach

One could set up a dynamic-programming algorithm to run backward in time starting from the final hour to be studied, back to the initial hour. Conversely, one could set up the algorithm to run forward in time from the initial hour to the final hour. The forward approach has distinct advantages in solving generator unit commitment. For example, if the start-up cost of a unit is a function of the time it has been off-line (i.e., its temperature), then a forward dynamic-program approach is more suitable since the previous history of the

unit can be computed at each stage. There are other practical reasons for going forward. The initial conditions are easily specified and the computations can go forward in time as long as required. A forward dynamic-programming algorithm is shown by the flowchart

The recursive algorithm to compute the minimum cost in hour  $K$  with combinati

$$F_{\text{cost}}(K,I) = \min[P_{\text{cost}}(K,I) + S_{\text{cost}}(K-1,L:K,I) + F_{\text{cost}}(K-1,L)] \text{ ----- (20)}$$

$F_{\text{cost}}(K, I)$  = least total cost to arrive at state  
( $K, I$ )

$P_{\text{cost}}(K,I)$  = production cost for  
state( $K, I$ )

$S_{\text{cost}}(K - 1, L: K, I)$  = transition cost from state ( $K - 1, L$ ) to  
state( $K, I$ )

State ( $K, I$ ) is the  $Z$ th combination in hour  $K$ . For the forward dynamic programming approach, we define a **strategy** as the transition, or path, from one state at a given hour to a state at the next hour.

Note that two new variables,  $X$  and  $N$ , have been introduced

$X$  = number of states to search each  
period

$N$  = number of strategies, or paths, to save  
ateach step

These variables allow control of the computational effort (see below Figure). For complete enumeration, the maximum number of the value of  $X$  or  $N$  is  $2^n - 1$

**Compute the minimum cost**

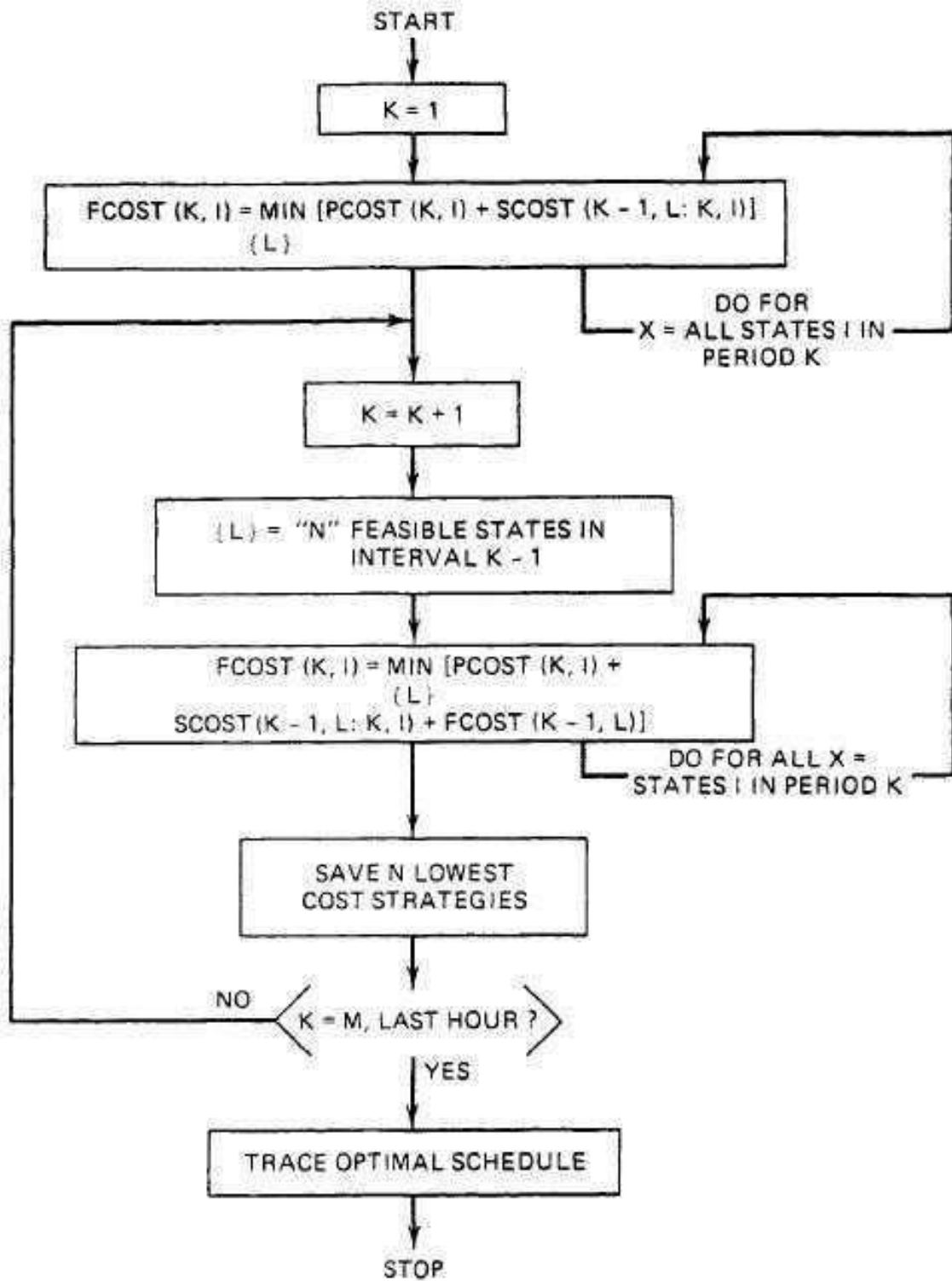

Figure: Forward DP Approach



**UNIT – V**

**COMPUTER CONTROL OF**  
**POWER SYSTEMS**

## **ENERGY CONTROL CENTRE**

The energy control center (ECC) has traditionally been the decision-center for the electric transmission and generation interconnected system. The ECC provides the functions necessary for monitoring and coordinating the minute-by-minute physical and economic operation of the power system. In the continental U.S., there are only three interconnected regions: Eastern, Western, and Texas, but there are many *control areas*, with each control area having its own ECC.

Maintaining integrity and economy of an inter-connected power system requires significant coordinated decision-making. So one of the primary functions of the ECC is to monitor and regulate the physical operation of the interconnected grid.

Most areas today have a two-level hierarchy of ECCs with the Independent System Operator (ISO) performing the high-level decision-making and the transmission owner ECC performing the lower-level decision-making.

A high-level view of the ECC is illustrated. Where we can identify the substation, the remote terminal unit (RTU), a communication link, and the ECC which contains the energy management system (EMS). The EMS provides the capability of converting the data received from the substations to the types of screens observed.

In these notes we will introduce the basic components and functionalities of the ECC. Note that there is no chapter in your text which provides this information.

### **Regional load control centre:**

It decides generation allocation to various generating stations within the region on the basis of equal incremental operating cost considering line losses are equal and Frequency control in the region.

### **Plant load control room:**

It decides the allocation of generation of various units in the plant on the basis of:

1. Equal incremented operating cost of various units
2. Minimize the reactive power flow through line so as to minimize line loss and maintain voltage levels and Frequency control in the plant.

## ECC Components

The system control function traditionally used in electric utility operation consists of three main integrated subsystems: the energy management system (EMS), the supervisory control and data acquisition (SCADA), and the communications interconnecting the EMS and the SCADA (which is often thought of as part of the SCADA itself). Figure 3 provides a block diagram illustration of these three integrated subsystems. The SCADA and communications subsystems are indicated in the dotted ovals at the top left hand corner of the figure. The rest of the figure indicates the EMS. We will describe each one in the following subsections.

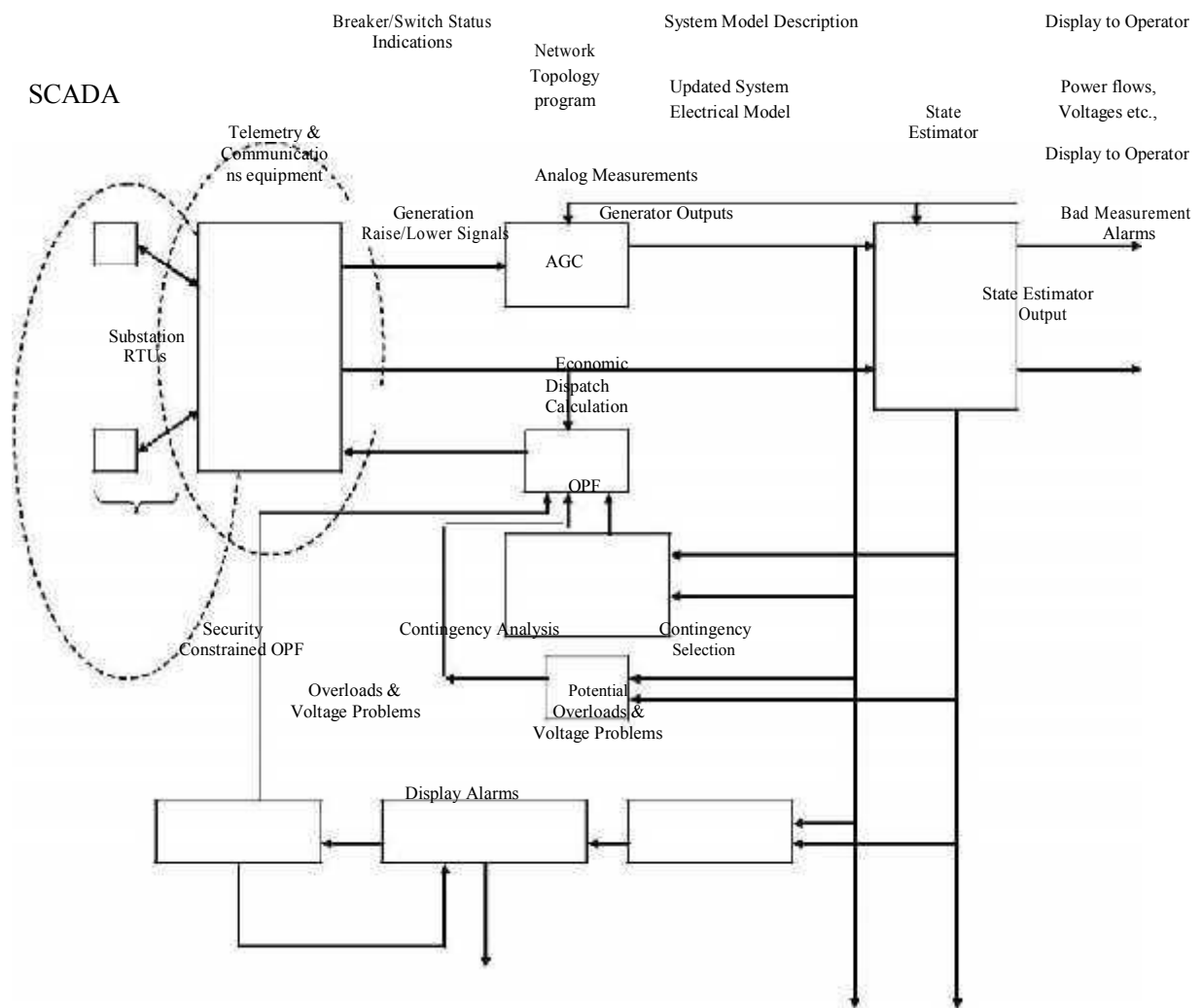

We distinguish EMS from distribution management systems (DMS). Both utilize their own SCADA, but for different functions. Whereas EMS/SCADA serves the high voltage bulk

transmission system from the ECC, the DMS/SCADA serves the low voltage, distribution system from a distribution dispatch center. We are addressing in these notes the EMS/SCADA.

### **Operation of control centre:**

- **Monitoring**
- **Data acquisition and Remote control**

### **level control**

1. Turbine – governor to adjust generation to balance changing load-instantaneous control.
2. AGC (called load frequency control (LFC)) maintains frequency and net power interchange.
3. Economic Dispatch Control (EDC) distributes the load among the units such that fuel cost is minimum.

### **B. Primary Voltage control**

1. Excitation control
2. Transmission voltage control, SVC, Shunt capacitors, transformer taps...

-----

## **2. SUPERVISORY CONTROL AND DATA ACQUISITION (SCADA)**

There are two parts to the term SCADA. *Supervisory control* indicates that the operator, residing in the energy control center (ECC), has the ability to control remote equipment. *Data acquisition* indicates that information is gathered characterizing the state of the remote equipment and sent to the ECC for monitoring purposes.

The monitoring equipment is normally located in the substations and is consolidated in what is known as the remote terminal unit (RTU). Generally, the RTUs are equipped with microprocessors having memory and logic capability. Older RTUs are equipped with modems to provide the communication link back to the ECC, whereas newer RTUs generally have intranet or internet capability.

Relays located within the RTU, on command from the ECC, open or close selected control circuits to perform a supervisory action. Such actions may include, for example, opening or closing of a circuit breaker or switch, modifying a transformer tap setting, raising



or lowering generator MW output or terminal voltage, switching in or out a shunt capacitor or inductor, and the starting or stopping of a synchronous condenser.

Information gathered by the RTU and communicated to the ECC includes both analog information and status indicators. Analog information includes, for example, frequency, voltages, currents, and real and reactive power flows. Status indicators include alarm signals (over-temperature, low relay battery voltage, illegal entry) and whether switches and circuit breakers are open or closed. Such information is provided to the ECC through a periodic scan of all RTUs. A 2 second scan cycle is typical.

### **Functions of SCADA Systems**

1. Data acquisition
2. Information display.
3. Supervisory Control (CBs:ON/OFF, Generator: stop/start, RAISE/LOWER command)
4. Information storage and result display.
5. Sequence of events acquisition.
6. Remote terminal unit processing.
7. General maintenance.
8. Runtime status verification.
9. Economic modeling.
10. Remote start/stop.
11. Load matching based on economics.
12. Load shedding.

- **Control functions**

- Control and monitoring of switching devices, tapped transformers, auxiliary devices, etc.
- Bay-and a station-wide interlocking Automatic functions such as load shedding, power restoration, and high speed bus bar transfer
- Time synchronization by radio and satellite clock signal

- **Monitoring functions:**

- Measurement and displaying of current, voltage, frequency, active and reactive power, energy, temperature, etc.
- Alarm functions. Storage and evaluation of time stamped events.

- **Protection functions:**

- Substation protection functions includes the monitoring of events like start, trip



Protection of bus bars. Line feeders, transformers, generators.

### **Communication technologies**

The form of communication required for SCADA is *telemetry*. Telemetry is the measurement of a quantity in such a way so as to allow interpretation of that measurement at a distance from the primary detector. The distinctive feature of telemetry is the nature of the translating means, which includes provision for converting the measure into a representative quantity of another kind that can be transmitted conveniently for measurement at a distance. The actual distance is irrelevant.

Telemetry may be analog or digital. In analog telemetry, a voltage, current, or frequency proportional to the quantity being measured is developed and transmitted on a communication channel to the receiving location, where the received signal is applied to a meter calibrated to indicate the quantity being measured, or it is applied directly to a control device such as a ECC computer.

Forms of analog telemetry include variable current, pulse-amplitude, pulse-length, and pulse-rate, with the latter two being the most common. In digital telemetry, the quantity being measured is converted to a code in which the sequence of pulses transmitted indicates the quantity. One of the advantages to digital telemetering is the fact that accuracy of data is not lost in transmitting the data from one location to another. Digital telemetry requires analog to digital (A/D) and possible digital to analog (D/A) converters, as illustrated in

The earliest form of signal circuit used for SCADA telemetry consisted of twisted pair wires; although simple and economic for short distances, it suffers from reliability problems due to breakage, water ingress, and ground potential risk during faults

Improvements over twisted pair wires came in the form of what is now the most common, traditional type of telemetry mediums based on leased-wire, power-line carrier, or microwave. These are *voice grade* forms of telemetry, meaning they represent communication channels suitable for the transmission of speech, either digital or analog, generally with a frequency range of about 300 to 3000 Hz

**SCADA requires communication between Master control station and Remote control station:**

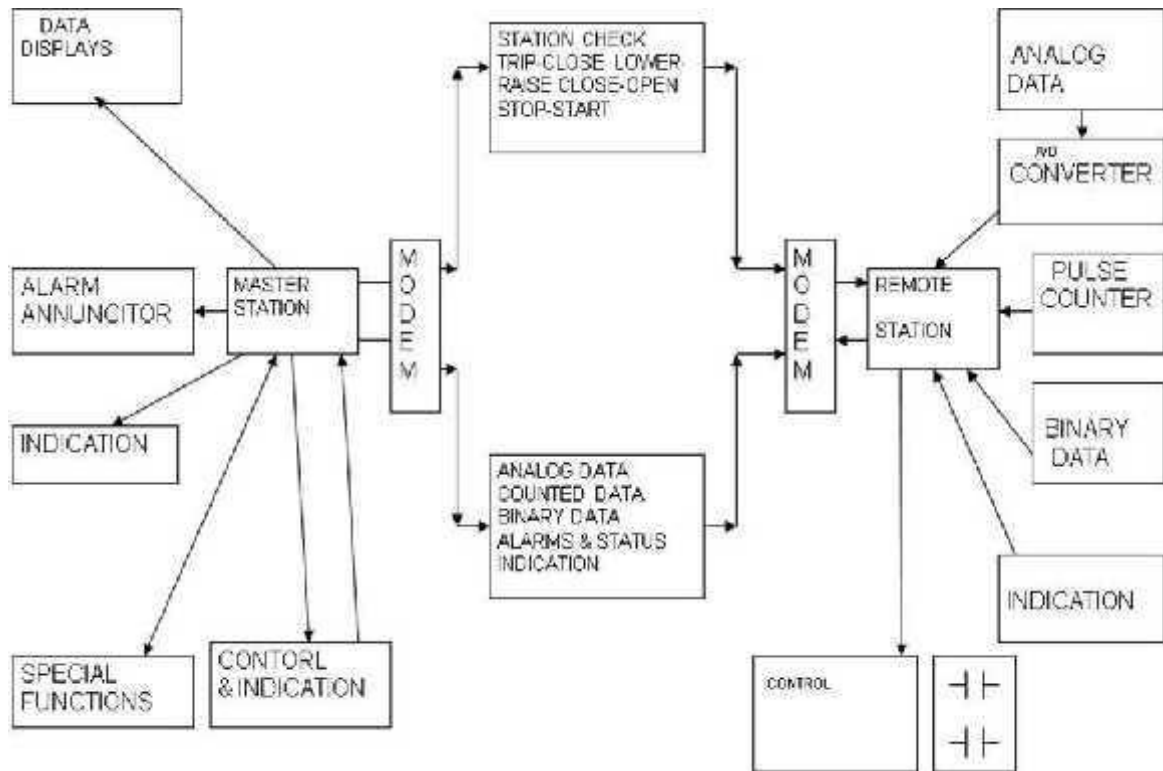

**Master and Remote station**

Leased-wire means use of a standard telephone circuit; this is a convenient and straightforward means of telemetry when it is available, although it can be unreliable, and it requires a continual outlay of leasing expenditures. In addition, it is not under user control and requires careful coordination between the user and the telephone company. Power-line carrier (PLC) offers an inexpensive and typically more reliable alternative to leased-wire. Here, the transmission circuit itself is used to modulate a communication signal at a frequency much greater than the 60 Hz power frequency. Most PLC occurs at frequencies in the range of 30-500 kHz. The security of PLC is very high since the communication equipment is located inside the substations.

through open disconnects, i.e., when the transmission line is outaged. Often, this is precisely the time when the communication signal is needed most. In addition, PLC is susceptible to line noise and requires careful signal-to-noise ratio analysis. Most PLC is strictly analog although digital PLC has become available from a few suppliers during the last few years.

Microwave radio refers to ultra-high-frequency (UHF) radio systems operating above

1 GHz. The earliest microwave telemetry was strictly analog, but digital microwave communication is now quite common for EMS/SCADA applications. This form of communication has obvious advantages over PLC and leased wire since it requires no physical conducting medium and therefore no right-of-way. However, line of sight clearance is required in order to ensure reliable communication, and therefore it is not applicable in some cases.

A more recent development has concerned the use of fiber optic cable, a technology capable of extremely fast communication speeds. Although cost was originally prohibitive, it has now decreased to the point where it is viable. Fiber optics may be either run inside underground power cables or they may be fastened to overhead transmission line towers just below the lines. They may also be run within the shield wire suspended above the transmission lines.

One easily sees that communication engineering is very important to power system control. Students specializing in power and energy systems should strongly consider taking communications courses to have this background. Students specializing in communication should consider taking power systems courses as an application area.

## **ENERGY MANAGEMENT SYSTEM (EMS)**

The EMS is a software system. Most utility companies purchase their EMS from one or more EMS vendors. These EMS vendors are companies specializing in design, development, installation, and maintenance of EMS within ECCs. There are a number of EMS vendors in the U.S., and they hire many power system engineers with good software development capabilities.

During the time period of the 1970s through about 2000, almost all EMS software applications

An attractive alternative today is, however, the application service provider, where the software resides on the vendor's computer and control center personnel access it from the Internet. Benefits from this arrangement include application flexibility and reliability in the software system and reduced installation cost.

One can observe from Figure 3 that the EMS consists of 4 major functions: network model building (including topology processing and state estimation), security assessment, automatic generation control, and dispatch. These functions are described in more detail in the following subsections.

Energy management is the process of monitoring, coordinating, and controlling the generation, transmission and distribution of electrical energy. The physical plant to be managed includes generating plants that produce energy fed through transformers to the high-voltage transmission network (grid), interconnecting generating plants, and load centers. Transmission lines terminate at substations that perform switching, voltage transformation, measurement, and control. Substations at load centers transform to sub transmission and distribution levels. These lower-voltage circuits typically operate radially, i.e., no normally closed paths between substations through sub transmission or distribution circuits.(Underground cable networks in large cities are an exception.)

Since transmission systems provide negligible energy storage, supply and demand must be balanced by either generation or load. Production is controlled by turbine governors at generating plants, and automatic generation control is performed by control center computers remote from generating plants. Load management, sometimes called demand-

Side management, extends remote supervision and control to subtransmission and distribution circuits, including control of residential, commercial, and industrial loads.

#### **Functionality Power EMS:**

1. System Load Forecasting-Hourly energy, 1 to 7 days.
2. Unit commitment-1 to 7days.
3. Economic dispatch
4. Hydro-thermal scheduling- up to 7 days.
5. MW interchange evaluation- with neighboring system
6. Transmission loss minimization
7. Security constrained dispatch
8. Maintenance scheduling
9. Production cost calculation

## **Power System Data Acquisition and Control**

A SCADA system consists of a master station that communicates with remote terminal units (RTUs) for the purpose of allowing operators to observe and control physical plants. Generating plants and transmission substations certainly justify RTUs, and their installation is becoming more common in distribution substations as costs decrease. RTUs transmit device status and measurements to, and receive control commands and setpoint data from, the master station. Communication is generally via dedicated circuits operating in the range of 600 to 4800 bits/s with the RTU responding to periodic requests initiated from the master station (polling) every 2 to 10 s, depending on the criticality of the data.

The traditional functions of SCADA systems are summarized:

- Data acquisition: Provides telemetered measurements and status information to operator.

- Supervisory control: Allows operator to remotely control devices, e.g., open and close

circuit breakers. A “select before operate” procedure is used for greater safety.

- Tagging: Identifies a device as subject to specific operating restrictions and prevents unauthorized operation.

- Alarms: Inform operator of unplanned events and undesirable operating conditions. Alarms

are sorted by criticality, area of responsibility, and chronology.

Acknowledgment may be required

- Logging: Logs all operator entry, all alarms, and selected information.

- Load shed: Provides both automatic and operator-initiated tripping of load in response to system emergencies.

- Trending: Plots measurements on selected time scales.

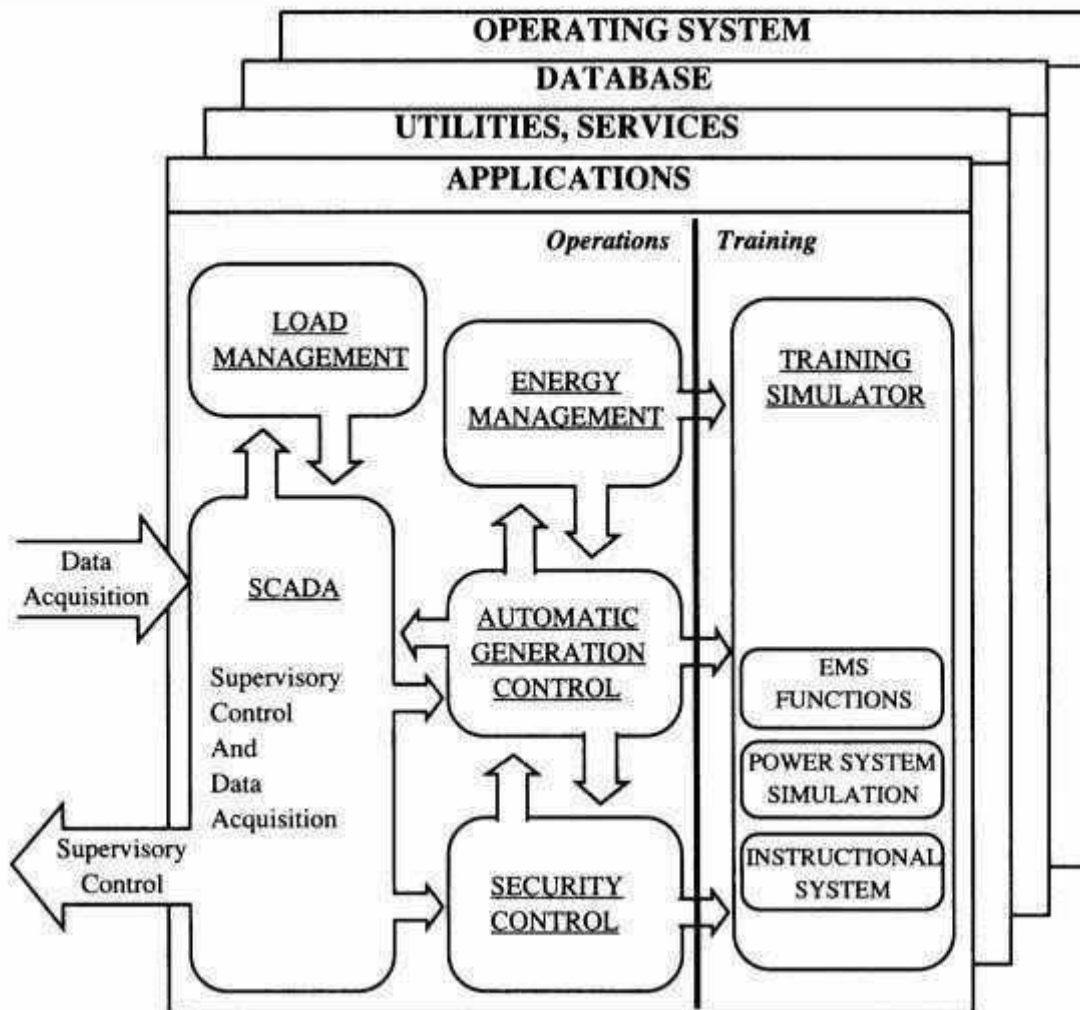

**Layers of a modern EMS.**

Since the master station is critical to power system operations, its functions are generally distributed among several computer systems depending on specific design. A dual computer system configured in primary and standby modes is most common. SCADA functions are listed below without stating which computer has specific responsibility.

- Manage communication circuit configuration
- Downline load RTU files
- Maintain scan tables and perform polling
- Check and correct message errors
- Convert to engineering units
- Detect status and measurement changes
- Monitor abnormal and out-of-limit conditions

- Log and time-tag sequence of events
- Detect and annunciate alarms



- Respond to operator requests to:
  - Display information
  - Enter data
  - Execute control action
  - Acknowledge alarms Transmit control action to RTUs
- Inhibit unauthorized actions
- Maintain historical files
- Log events and prepare reports
- Perform load shedding

### **Automatic Generation Control**

*Automatic generation control (AGC)* consists of two major and several minor functions that operate online in realtime to adjust the generation against load at minimum cost. The major functions are load frequency control and economic dispatch, each of which is described below. The minor functions are reserve monitoring, which assures enough reserve on the system; interchange scheduling, which initiates and completes scheduled interchanges; and other similar monitoring and recording functions.

### **Load Frequency Control**

Load frequency control (LFC) has to achieve three primary objectives, which are stated below in priority order:

1. To maintain frequency at the scheduled value
2. To maintain net power interchanges with neighboring control areas at the scheduled values
3. To maintain power allocation among units at economically desired values.

The first and second objectives are met by monitoring an error signal, called *area control error (ACE)*, which is a combination of net interchange error and frequency error and represents the power imbalance between generation and load at any instant. This ACE must be filtered or smoothed such that excessive and random changes in ACE are not translated into control action. Since these excessive changes are different for different systems, the filter

parameters have to be tuned specifically for each control area.

The filtered ACE is then used to obtain the proportional plus integral control signal. This control signal is modified by limiters, deadbands, and gain constants that are tuned to the particular system. This control signal is then divided among the

generating units under control by using participation factors to obtain *unit control errors* (UCE).

These participation factors may be proportional to the inverse of the second derivative of the cost of unit generation so that the units would be loaded according to their costs, thus meeting the third objective. However, cost may not be the only consideration because the different units may have different response rates and it may be necessary to move the faster generators more to obtain an acceptable response. The UCEs are then sent to the various units under control and the generating units monitored to see that the corrections take place. This control action is repeated every 2 to 6 s. In spite of the integral control, errors in frequency and net interchange do tend to accumulate over time. These time errors and accumulated interchange errors have to be corrected by adjusting the controller settings according to procedures agreed upon by the whole interconnection. These accumulated errors as well as ACE serve as performance measures for LFC.

The main philosophy in the design of LFC is that each system should follow its own load very closely during normal operation, while during emergencies; each system should contribute according to its relative size in the interconnection without regard to the locality of the emergency. Thus, the most important factor in obtaining good control of a system is its inherent capability of following its own load. This is guaranteed if the system has adequate regulation margin as well as adequate response capability. Systems that have mainly thermal generation often have difficulty in keeping up with the load because of the slow response of the units.

## **SECURITY ANALYSIS & CONTROL:**

Security monitoring is the on line identification of the actual operating conditions of a power system. It requires system wide instrumentation to gather the system data as well as a means for the on line determination of network topology involving an open or closed position of circuit breakers. A state estimation has been developed to get the best estimate of the status

.the state estimation provides the database for security analysis shown in fig.5.6.





## **System Security**

1. System monitoring.
2. Contingency analysis.
3. Security constrained optimal power flow

## **Security Assessment**

Security assessment determines first, whether the system is currently residing in an acceptable state and second, whether the system would respond in an acceptable manner and reach an acceptable state following any one of a pre-defined contingency set. A *contingency* is the unexpected failure of a transmission line, transformer, or generator. Usually, contingencies result from occurrence of a *fault*, or short-circuit, to one of these components. When such a fault occurs, the protection systems sense the fault and remove the component, and therefore also the fault, from the system. Of course, with one less component, the overall system is weaker, and undesirable effects may occur. For example, some remaining circuit may overload, or some bus may experience an undervoltage condition. These are called *static* security problems.

*Dynamic* security problems may also occur, including uncontrollable voltage decline, generator overspeed (loss of synchronism), or undamped oscillatory behavior.

## **Security Control**

Power systems are designed to survive all probable contingencies. A contingency is defined as an event that causes one or more important components such as transmission lines, generators, and transformers to be unexpectedly removed from service. Survival means the system stabilizes and continues to operate at acceptable voltage and frequency levels without loss of load. Operations must deal with a vast number of possible conditions experienced by the system, many of which are not anticipated in planning. Instead of dealing with the impossible task of analyzing all possible system states, security control starts with a specific state: the current state if executing the real-time network sequence; a postulated state if executing a study sequence. Sequence means sequential execution of programs that perform the following steps:

1. Determine the state of the system based on either current or postulated conditions.
2. Process a list of contingencies to determine the consequences of each contingency on the system in its specified state.

3. Determine preventive or corrective action for those contingencies which represent unacceptable risk.

Security control requires topological processing to build network models and uses large-scale AC network analysis to determine system conditions. The required applications are grouped as a network subsystem that typically includes the following functions:

- **Topology processor:** Processes real-time status measurements to determine an electrical connectivity (bus) model of the power system network.

- **State estimator:** Uses real-time status and analog measurements to determine the "best" estimate

of the state of the power system. It uses a redundant set of measurements; calculates voltages, phase angles, and power flows for all components in the system; and reports overload conditions.

- **Power flow:** Determines the steady-state conditions of the power system network for a specified generation and load pattern. Calculates voltages, phase angles, and flows across the entire system.

- **Contingency analysis:** Assesses the impact of a set of contingencies on the state of the power system and identifies potentially harmful contingencies that cause operating limit violations.

**Optimal power flow:** Recommends controller actions to optimize a specified objective function (such as system operating cost or losses) subject to a set of power system operating constraints.

- **Security enhancement:** Recommends corrective control actions to be taken to alleviate an existing or potential overload in the system while ensuring minimal operational cost.

- **Preventive action:** Recommends control actions to be taken in a "preventive" mode before a

contingency occurs to preclude an overload situation if the contingency were to occur.

- **Bus load forecasting:** Uses real-time measurements to adaptively forecast loads for the electrical connectivity (bus) model of the power system network

- **Transmission loss factors:** Determines incremental loss sensitivities for generating units; calculates the impact on losses if the output of a unit were to be increased by 1 MW.

- **Short-circuit analysis:** Determines fault currents for single-phase and three-phase faults for fault locations across the entire power system network.

*Real-time Network Analysis Sequence*

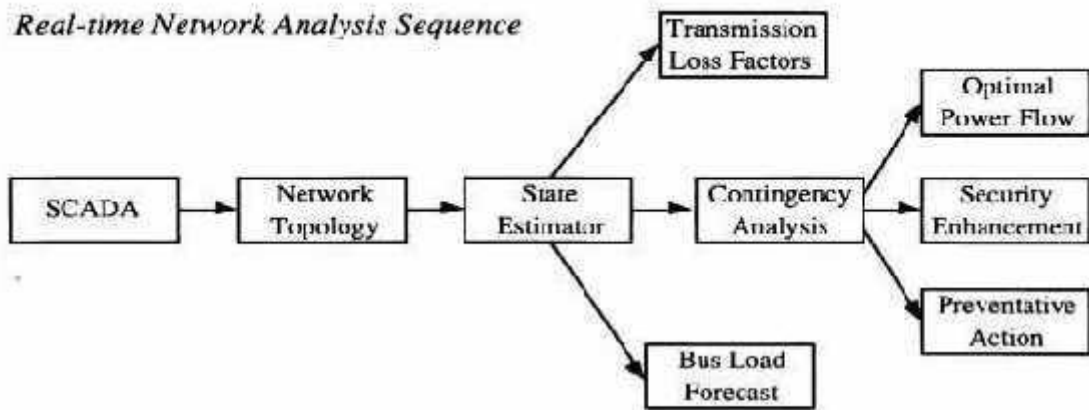

*Study Network Analysis*



**VARIOUS OPERATING STATES:**

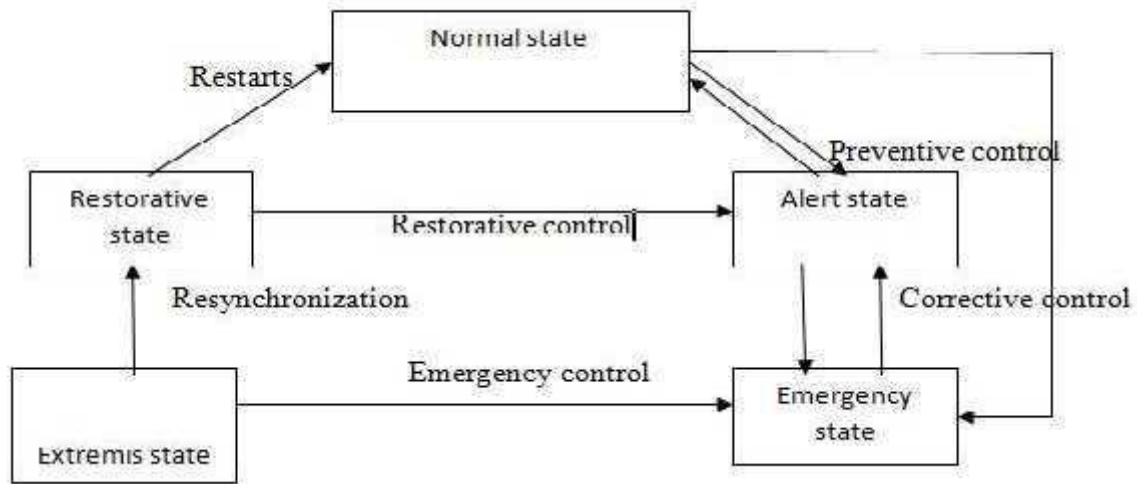

**Operating states**

1. Normal state
2. Alert state
3. Emergency state
4. Extremis state
5. Restorative state

➤ **Normal state:**

A system is said to be in normal if both load and operating constraints are satisfied .It is one in which the total demand on the system is met by satisfying all the operating constraints.



➤ **Alert state:**

A normal state of the system said to be in alert state if one or more of the postulated contingency states, consists of the constraint limits violated. When the system security level falls below a certain level or the probability of disturbance increases, the system may be in alert state. All equalities and inequalities are satisfied, but on the event of a disturbance, the system may not have all the inequality constraints satisfied. If severe disturbance occurs, the system will push into emergency state. To bring back the system to secure state, preventive

control action is carried out.



**Emergency state:**

The system is said to be in emergency state if one or more operating constraints are violated, but the load constraint is satisfied. In this state, the equality constraints are unchanged. The system will return to the normal or alert state by means of corrective actions, disconnection of faulted section or load sharing.



**Extremis state:**

When the system is in emergency, if no proper corrective action is taken in time, then it goes to either emergency state or extremis state. In this regard neither the load or nor the operating

constraint is satisfied, this result is islanding. Also the generating units are strained beyond their capacity. So emergency control action is done to bring back the system state either to the

emergency state or normal state.



**Restorative state:**

From this state, the system may be brought back either to alert state or secure state. The latter is a slow process. Hence, in certain cases, first the system is brought back to alert state and then to the secure state. This is done using restorative control action

