

UNIT 1

SCIENCE OF MEASUREMENTS

GENERAL CONFIGURATION AND FUNCTIONAL DESCRIPTION OF MEASURING INSTRUMENTS

A systematic organization and analysis are more important for measurement systems. The whole operation system can be described in terms of functional elements. The functional elements of generalized measurement system.

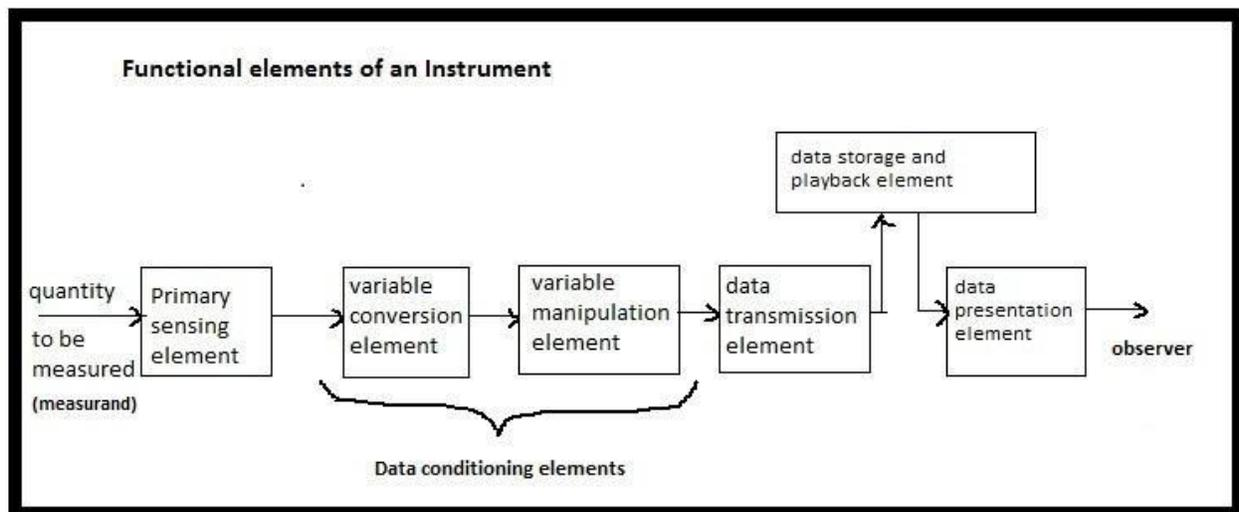

Most of the measurement system consists of following functional elements.

1. Primary sensing element
2. Variable conversion element
3. Variable manipulation element
4. Data transmission element
5. Data storage and playback element
6. Data presentation element

1. Primary Sensing Element

The quantity under measurement makes its first contact with primary sensing element of measurement system. The quantity is first sensed or detected by primary sensor. Then detected physical quantity signal is converted into an electrical signal by a transducer. *Transducer is defined as a device which converts a physical quantity into an electrical quantity. Sensor is act as primary element of transducer.* In many cases the physical quantity is directly converted into an electrical quantity by a transducer. So the first stage of a measurement system is known as a *detector transducer stage*.

Example, Pressure transducer with pressure sensor, Temperature sensor ect.,

2. Variable Conversion Element

The output of primary sensing element is electrical signal of any form like a voltage, a frequency or some other electrical parameter. Sometime this output not suitable for next level of system. So it is necessary to convert the output some other suitable form while maintaining the original signal to perform the desired function the system.

For example the output primary sensing element is in analog form of signal and next stage of system accepts only in digital form of signal. So, we have to convert analog signal into digital form using an A/D converter. Here *A/D converter* is act as variable conversion element.

3. Variable Manipulation Element

The function of variable manipulation element is to manipulate the signal offered but original nature of signal is maintained in same state. Here manipulation means only *change in the numerical value of signal*.

Examples,

1. *Voltage amplifier* is act as variable manipulation element. Voltage amplifier accepts a small voltage signal as input and produces the voltage with greater magnitude .Here numerical value of voltage magnitude is increased.

2. *Attenuator* acts as variable manipulation element. It accepts a high voltage signal and produces the voltage or power with lower magnitude. Here numerical value of voltage magnitude is decreased.

Linear process manipulation elements: Amplification, attenuation, integration, differentiation, addition and subtraction ect.,

Nonlinear process manipulation elements: Modulation, detection, sampling, filtering, chopping and clipping ect.,

All these elements are performed on the signal to bring it to desired level to be accepted by the next stage of measurement system. This process of conversion is called *signal conditioning*. The combination of variable conversion and variable manipulation elements are called as *Signal Conditioning Element*.

4. Data Transmission Element

The elements of measurement system are actually physically separated; it becomes necessary to transmit the data from one to another. The element which performs this function is called as data transmission element.

Example, Control signals are transmitted from earth station to Space-crafts by a telemetry system using radio signals. Here telemetry system acts as data transmission element.

The combination of Signal conditioning and transmission element is known as *Intermediate Stage* of measurement system.

5. Data storage and playback element

Some applications require a separate data storage and playback function for easily rebuilding the stored data based on the command. The data storage is made in the form of pen/ink and digital recording. Examples, magnetic tape recorder/ reproducer, X-Y recorder, X-t recorder, Optical Disc recording etc.,

6. Data presentation Element

The function of this element in the measurement system is to communicate the information about the measured physical quantity to human observer or to present it in an understandable form for monitoring, control and analysis purposes.

Visual display devices are required for monitoring of measured data. These devices may be analog or digital instruments like ammeter, voltmeter, camera, CRT, printers, analog and digital computers.

Computers are used for control and analysis of measured data of measurement system. This

Final stage of measurement system is known as *Terminating stage*.

EXAMPLE OF GENERALIZED MEASUREMENT SYSTEM

Example 1. Bourdon Tube Pressure Gauge:

The simple pressure measurement system using Bourdon tube pressure gauge is shown in .The detail functional elements of this pressure measurement system is given below.

Quantity to be measured : Pressure Primary sensing element and

Variable conversion element : Bourdon Tube

Data Transmission element : Mechanical Linkages

Variable manipulation Element : Gearing arrangement

Data presentation Element : Pointer and Dial

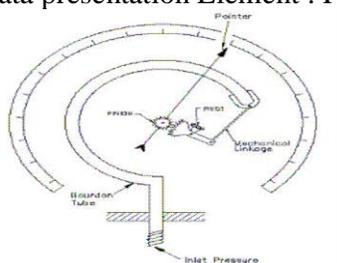

Bourdon tube pressure gauge

In this measurement system, Bourdon tube acts as primary sensing and variable conversion element. The input pressure is sensed and converted into small displacement by a

bourdon tube. On account of input pressure the closed end of the tube is displaced. Because of this pressure is converted into small displacement. The closed end of bourdon tube is connected through mechanical linkage to a gearing arrangement.

The small displacement signal can be amplified by gearing arrangement and transmitted by mechanical linkages and finally it makes the pointer to rotate on a large angle of scale. If it is calibrated with known input pressure, gives the measurement of the pressure signal applied to the bourdon tube in measured

CHARACTERISTICS OF INSTRUMENT - STATIC CHARACTERISTICS - DYNAMIC CHARACTERISTICS

Characteristics of Measuring Instruments: These performance characteristics of an instrument are very important in their selection.

Static Characteristics: Static characteristics of an instrument are considered for instruments which are used to measure an unvarying process condition. Performance criteria based upon static relations represent the static Characteristics. (The static characteristics are the value or performance given after the steady state condition has reached).

Dynamic Characteristics: Dynamic characteristics of an instrument are considered for instruments which are used to measure a varying process condition. Performance criteria based upon dynamic relations represent the dynamic Characteristics.

Static Characteristics:

- 1) **Accuracy:** Accuracy is defined as the degree of closeness with which an instrument reading approaches to the true value of the quantity being measured. It determines the closeness to true value of instrument reading. Accuracy is represented by percentage of full scale reading or in terms of inaccuracy or in terms of error value. Example, Accuracy of temperature measuring instrument might be specified by $\pm 3^\circ\text{C}$. This accuracy means the temperature reading might be within + or -3°C deviation from the true value. Accuracy of an instrument is specified by $\pm 5\%$ for the range of 0 to 200°C in the temperature scale means the reading might be within + or -10°C of the true reading.
- 2) **Precision:** Precision is the degree of repeatability of a series of the measurement. Precision is measures of the degree of closeness of agreement within a group of measurements are repeatedly made under the prescribed condition. Precision is used in measurements to describe the stability or reliability or the reproducibility of results.

Comparison between accuracy and precision.

S.No	Accuracy	Precision
1.	It refers to degree of closeness of the measured value to the true value.	It refers to the degree of agreement among group of readings
2.	Accuracy gives the maximum error that is maximum departure of the final result from its true value.	Precision of a measuring system gives its capability to reproduce a certain reading with a given accuracy

3) **Bias:** Bias is quantitative term describing the difference between the average of measured readings made on the same instrument and its true value (It is a characteristic of measuring instruments to give indications of the value of a measured quantity for which the average value differs from true value).

4) **Sensitivity:** Sensitivity is defined as the ratio of change in output signal (response) to the change in input signal (measured). It is the relationship indicating how much output changes when input changes. Sensitivity=change in output change in input $Sensitivity = \frac{\Delta q_o}{\Delta q_i}$ If the sensitivity is constant then the system is said to be linear system. If the sensitivity is variable then the system is said to be non linear system.

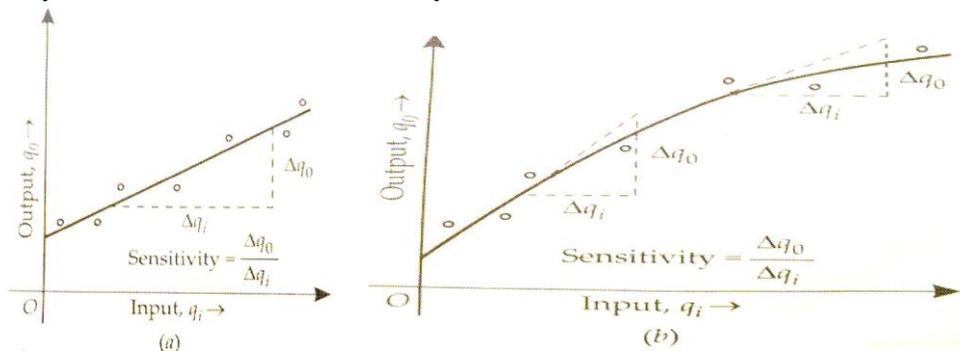

Definition of sensitivity for (a) Linear and (b) Non linear instrument When the calibration curve is linear as the sensitivity of the instrument can be defined as in slope of the calibration curve. In this case sensitivity is constant over the entire range of instrument. If the curve is not normally straight line or nonlinear instrument sensitivity varies with the input or varies from one range to another.

5) **Linearity:** Linearity is the best characteristics of an instrument or measurement system. Linearity of the instrument refers to the output is linearly or directly proportional to input over the entire range of instrument. So the degree of linear (straight line) relationship between the output to input is called as linearity of an instrument.

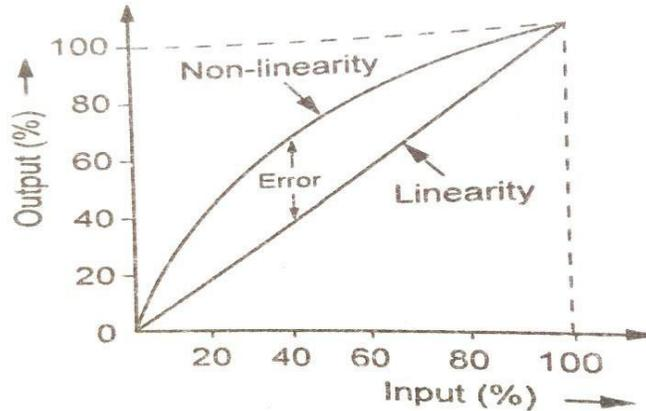

Representation of Linearity and Non-Linearity of an Instrument

Nonlinearity: The maximum difference or deviation of output curve from the Specified idealized straight line as shown in figure 4.2. Independent nonlinearity may be defined as Non linearity=Maximum deviation of output from the idealized straight line Actual reading or response X 100

5) **Resolution:** Resolution or Discrimination is the smallest change in the input value that is required to cause an appreciable change in the output. (The smallest increment in input or input change which can be detected by an instrument is called as resolution or discrimination.)

6) **Hysteresis:** Hysteresis is Non-coincidence of loading and unloading curves on output. Hysteresis effect shows up in any physical, chemical or electrical phenomenon When input increases, output also increases and calibration curve can be drawn. If input is decreases from maximum value and output also decreases but does not follow the same curve, then there is a residual output when input is zero. This phenomenon is called Hysteresis. The difference between increasing change and decreasing change of output values is known as hysteresis error. (The different outputs from the same value of quantity being measured are reached by

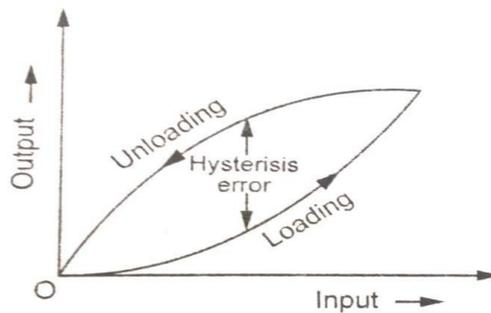

Hysteresis Error of an instrument

7) **Dead Zone:** Dead zone or dead band is defined as the largest change of input quantity for which there is no output the instrument due the factors such as friction, backlash and hysteresis within the system.(The region upto which the instrument does not respond for an input change is

called dead zone) *Dead time* is the time required by an instrument to begin to respond to change in input quantity.

8) **Backlash:** The maximum distance through which one part of the instrument is moved without disturbing the other part is called as backlash. (Backlash may be defined as the maximum distance or angle through which any part of the instrument can be moved without causing any motion of next part of the system)

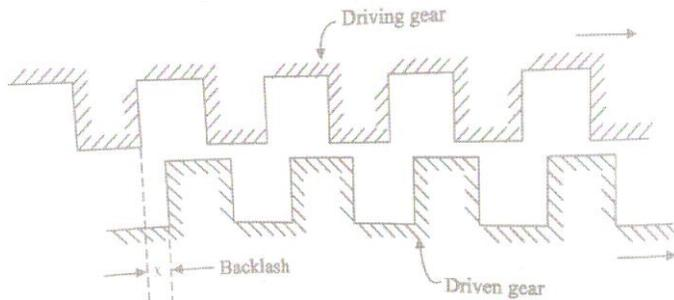

Threshold because of backlash

Reasons for the presence of backlash in an instrument include allowing for lubrication, manufacturing errors, deflection under load, and thermal expansion. 9) **Drift:** Drift is an undesirable change in output over a period of time that is unrelated to change in input, operating conditions. Drift is occurred in instruments due to internal temperature variations, ageing effects and high stress ect. Zero drift is used for the changes that occur in output when there is zero output. It is expressed as percentage of full range output.

10) **Threshold:** The minimum value of input which is necessary to activate an instrument to produce an output is termed its *threshold* as shown in figure 1.5. (Threshold is the minimum value of the input required to cause the pointer to move from zero position).

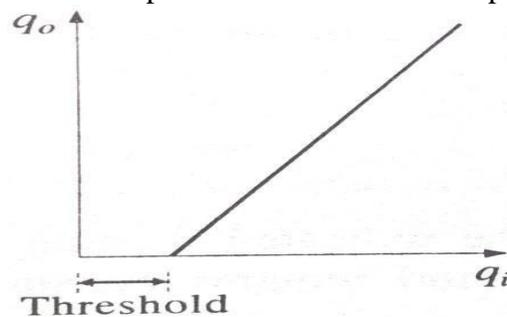

Threshold effect

11) **Input Impedance:** The magnitude of the impedance of element connected across the signal source is called Input Impedance. voltage signal source and input device connected across it.

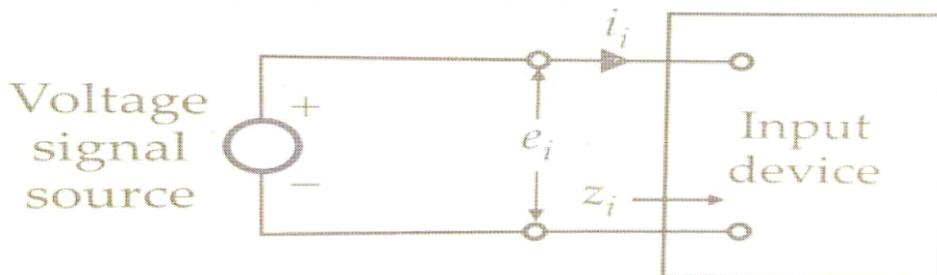

voltage source and input device

The magnitude of the input impedance is given by $Z_i = e_{i1} / i_{i1}$. Power extracted by the input device from the signal source is $P = e_{i1} i_{i1} = e_i^2 / Z_i$. From above two expressions it is clear that a low input impedance device connected across the voltage signal source draws more current and more power from signal source than high input impedance device.

12) Loading Effect: Loading effect is the incapability of the system to faithfully measure, record or control the input signal in accurate form.

13) Repeatability: Repeatability is defined as the ability of an instrument to give the same output for repeated applications of same input value under same environmental condition.

14) Reproducibility: Reproducibility is defined as the ability of an instrument to reproduce the same output for repeated applications of same input value under different environment condition. In case of perfect reproducibility the instrument satisfies no drift condition.

Dynamic Characteristics:

The dynamic behavior of an instrument is determined by applying some standard form of known and predetermined input to its primary element (sensing element) and then studies the output. Generally dynamic behavior is determined by applying following three types of inputs.

1. **Step Input:** Step change in which the primary element is subjected to an instantaneous and finite change in measured variable

2. **Linear Input:** Linear change, in which the primary element is, follows a measured variable, changing linearly with time.

3. **Sinusoidal input:** Sinusoidal change, in which the primary element follows a measured variable, the magnitude of which changes in accordance with a sinusoidal function of constant amplitude.

The dynamic characteristics of an instrument are (i) Speed of response, (ii) Fidelity, (iii) Lag, and (iv) Dynamic error.

(i) **Speed of Response:** It is the rapidity with which an instrument responds to changes in the measured quantity.

(ii) **Fidelity:** It is the degree to which an instrument indicates the changes in the measured variable without dynamic error (faithful reproduction or fidelity of an instrument is the ability of reproducing an input signal faithfully (truly)).

(iii) **Lag:** It is the retardation or delay in the response of an instrument to changes in the measured variable. The measuring lags are two types:

Retardation type: In this case the response of an instrument begins immediately after a change in measured variable is occurred.

Time delay type: In this case the response of an instrument begins after a dead time after the application of the input quantity.

(iv) **Dynamic Error:** It is the difference between the true values of a quantity changing with time and the value indicated by the instrument, if no static error is assumed. It is also called as

Measurement Error. When measurement problems are concerned with rapidly varying quantities, the dynamic relations between the instruments input and output are generally defined by the use of differential equations.

TYPES OF ERRORS:

All measurement can be made without perfect accuracy (degree of error must always be assumed). In reality, no measurement can ever be made with 100% accuracy. It is important to find that actual accuracy and different types of errors can be occurred in measuring instruments. Errors may arise from different sources and usually classified as follows,

Classification of Error

- Gross Errors
- Systematic Errors
 - 1. Instrumental errors
 - i. Inherent shortcomings of instruments
 - ii. Misuse of instruments
 - iii. Loading effects
 - 2. Environmental errors
 - 3. Observational errors
- Random Errors

1. Gross Errors:

The main source of Gross errors is human mistakes in reading or using instruments and in recording and calculating measured quantity. As long as human beings are involved and they may grossly misread the scale reading, then definitely some gross errors will be occurred in measured value.

Example, Due to an oversight, Experimenter may read the temperature as 22.7°C while the actual reading may be 32.7°C. He may transpose the reading while recording. For example, he may read 16.7°C and record 27.6°C as an alternative.

The complete elimination of gross errors is maybe impossible, one should try to predict and correct them. Some gross errors are easily identified while others may be very difficult to detect. Gross errors can be avoided by using the following two ways.

- Great care should be taken in reading and recording the data.

Two, three or even more readings should be taken for the quantity being measured by using different experimenters and different reading point (different environment condition of instrument) to avoid re-reading with same error. So it is suitable to take a large number of readings as a close agreement between readings assures that no gross error has been occurred in measured values.

2. Systematic Errors:

Systematic errors are divided into following three categories.

- i. Instrumental Errors
- ii. Environmental Errors
- iii. Observational Errors

i) Instrumental Errors

These errors arise due to following three reasons (sources of error).

- a) Due to inherent shortcoming of instrument
- b) Due to misuse of the instruments, and
- c) Due to loading effects of instruments

a) Inherent Shortcomings of instruments

- These errors are inherent in instruments because of their mechanical structure due to construction, calibration or operation of the instruments or measuring devices.
- These errors may cause the instrument to read too low or too high.

Example, if the spring (used for producing controlling torque) of a permanent magnet instrument has become weak, so the instrument will always read high.

Errors may be caused because of friction, hysteresis or even gear backlash.

Elimination or reduction methods of these errors,

- The instrument may be re-calibrated carefully.
- The procedure of measurement must be carefully planned. Substitution methods or calibration against standards may be used for the purpose.
- Correction factors should be applied after determining the instrumental errors.

b) Misuse of Instruments

In some cases the errors are occurred in measurement due to the fault of the operator than that of the instrument. A good instrument used in an unintelligent way may give wrong results.

Examples, Misuse of instruments may be failure to do zero adjustment of instrument, poor initial adjustments, using leads of too high a resistance and ill practices of instrument beyond the manufacturer's instruction and specifications ect.

c) Loading Effects

The errors committed by loading effects due to improper use of an instrument for measurement work. In measurement system, loading effects are identified and corrections should be made or more suitable instruments can be used.

Example, a well calibrated voltmeter may give a misleading (may be false) voltage reading when connected across a high resistance circuit. The same voltmeter, when connected across a low resistance circuit may give a more reliable reading (dependable or steady or true value).

In this example, *voltmeter has a loading effect* on the circuit, altering the actual circuit conditions by measurement process. So errors caused by loading effect of the meters can be avoided by using them intelligently.

Environmental Error

Environmental error occurs due to external environmental conditions of the instrument, such as effects of temperature, pressure, humidity, dust, vibration or external magnetic or electrostatic fields.

Elimination or reduction methods of these undesirable errors are

Arrangements should be made to keep the conditions as nearly as constant as possible. Example, temperature can be kept constant by keeping the instrument in the temperature controlled region.

The device which is used against these environmental effects.

Example, variations in resistance with temperature can be minimized by using very low resistance temperature co-efficient of resistive material.

Employing techniques which eliminate the effects of these disturbances. For example, the effect of humidity dust etc., can be entirely eliminated by tightly sealing the equipment.

The external or electrostatic effects can be eliminated by using magnetic or electrostatic shield on the instrument.

Applying computed corrections: Efforts are normally made to avoid the use of application of computed corrections, but where these corrections are needed and are necessary, they are incorporated for the computations of the results

iii) Observational Errors

There are many sources of observational errors. As an example, the pointer of a voltmeter rests slightly above the surface of the scale. Thus an error on account of PARALLAX will be acquired unless the line of vision of the observer is exactly above the pointer. To minimize parallax errors highly accurate meters are provided with mirrored scales as shown in figure 2.1.

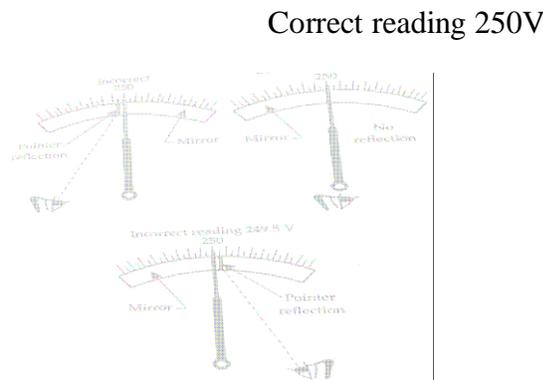

Errors due to parallax

When the pointer's image appears hidden by the pointer, observer's eye is directly in line with the pointer. Although a mirrored scale minimizes parallax error, an error is necessarily presented through it may be very small.

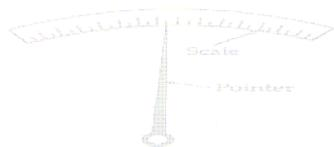

Arrangements showing scale and pointer in the same plane

The observational errors are also occurs due to involvement of human factors. For example, there are observational errors in measurements involving timing of an event Different observer may produce different results, especially when sound and light measurement are involved.

The complete elimination of this error can be achieved by using digital display of output.

3. Random Errors:

These errors are occurred due to unknown causes and are observed when the magnitude and polarity of a measurement fluctuate in changeable (random) manner.

The quantity being measure is affected by many happenings or disturbances and ambient influence about which we are unaware are lumped together and called as *Random* or *Residual*. The errors caused by these disturbances are called *Random Errors*. Since the errors remain even after the systematic errors have been taken care, those errors are called as *Residual (Random) Errors*.

Random errors cannot normally be predicted or corrected, but they can be minimized by skilled observer and using a well maintained quality instrument.

Errors in Measuring Instruments:

No measurement is free from error in reality. An intelligent skill in taking measurements is the ability to understand results in terms of possible errors. If the precision of the instrument is sufficient, no matter what its accuracy is, a difference will always be observed between two measured results. So an understanding and careful evaluation of the errors is necessary in measuring instruments. The Accuracy of an instrument is measured in terms of errors.

True value

The true value of quantity being measured is defined as the average of an infinite number of measured values when the average deviation due to the various contributing factors tends to zero.

In ideal situation is not possible to determine the True value of a quantity by experimental way. Normally an experimenter would never know that the quantity being measured by experimental way is the True value of the quantity or not.

In practice the true value would be determined by a “standard method”, that is a method agreed by experts with sufficient accurate.

Static Error

Static error is defined as a difference between the measured value and the true value of the quantity being measured. It is expressed as follows.

$$\delta A = A_m - A_t \text{ ----- (1)}$$

Where, δA = Error, A_m = Measured value of quantity and A_t = True value of quantity.

δA is also called as absolute static error of quantity A and it is expressed as follows.

$$\epsilon_0 = \delta A \text{ ----- (2)}$$

Where, ϵ_0 = Absolute static error of quantity A under measurement.

The absolute value of δA does not specify exactly the accuracy of measurement .so the quality of measurement is provided by relative static error.

Relative static error

Relative static error is defined as the ratio between the absolute static errors and true value of quantity being measured. It is expressed as follows.

$$\epsilon_r = \frac{\text{Absolute Error}}{\text{True Value}} = \frac{\delta A}{A_t} = \frac{\epsilon_0}{A_t} \text{ ----- (3)}$$

Percentage static error = % $\epsilon_r = \epsilon_r \times 100$

From equation (1), $A_t = A_m - \delta A$

$$A_t = A_m - \epsilon_0$$

$$A_t = A_m - \epsilon_r A_t \text{ ----- (4)}$$

$$A_t + \epsilon A_t = A_m$$

$$A_t (1 + \epsilon) = A_m \quad A_t = A_m / (1 + \epsilon)$$

When the absolute error $\epsilon = \delta A$ is small, which means that the difference between measured value and true values is very small, $A_m - A_t =$ Negligible or small. So Almost

$$A_m = A_t \quad (\text{that is } \epsilon \ll 1).$$

From equation (4), $A_t = A_m - \epsilon A_t$

Substitute $A_t = A_m$ in equation (4),

$$A_t = A_m - \epsilon A_m$$

$$A_t = A_m (1 - \epsilon)$$

Static error Correction or method of Correction:

It is the difference between the true value and the measured value of quantity.

$$\delta C = A_t - A_m \quad \text{----- (5)}$$

Where, $\delta C =$ Static Error Correction = $-\delta A$

* For Detail Error correction (Rectification or Elimination or Reduction) methods of all categories of errors are discussed in the topic of *classification of errors*.

Sources of Errors:

The sources of error, other than the inability of a piece of hardware to provide a true measurement are listed below,

- 1) Insufficient knowledge of process parameters and design conditions.
- 2) Poor design
- 3) Change in process parameters, irregularities, upsets (disturbances) ect.
- 4) Poor maintenance
- 5) Errors caused by people who operate the instrument or equipment.
- 6) Certain design limitations.

Statistical Evaluation of Measurement Data:

Statistical Evaluation of measured data is obtained in two methods of tests as shown in below.

Multi Sample Test: In multi sample test, repeated measured data have been acquired by different instruments, different methods of measurement and different observer.

Single Sample Test: measured data have been acquired by identical conditions (same instrument, methods and observer) at different times.

Statistical Evaluation methods will give the most probable true value of measured quantity. The mathematical background statistical evaluation methods are Arithmetic Mean, Deviation Average Deviation, Standard Deviation and variance.

LIMITING ERRORS (*Guarantee Errors or Limits of errors*):

In most of the instruments the accuracy is guaranteed to be within a certain percentage of full scale reading. The manufacturer has to specify the deviations from the *nominal value* of a particular quantity. The limits of these deviations from the specified value are called as *Limiting Errors* or *Guarantee Errors*.

The magnitude of Limiting Error = Accuracy x Full scale reading. In general the actual value of quantity is determined as follows.

$$\text{Actual Value of Quantity} = \text{Nominal value} \pm \text{Limiting Error}$$

$$A_a = A_n \pm \delta A$$

Where, A_a = Actual value of quantity; A_n = Nominal value of Quantity; $\pm \delta A$ = Limiting error.

For Example, Nominal magnitude of resistor is 1000Ω with a limiting error $\pm 100\Omega$. Determine the Actual magnitude of the resistance.

Actual value of quantity $A_a = 1000 \pm 100\Omega$ or $A_a \geq 900\Omega$ and $A_a \leq 1100\Omega$.

Therefore the manufacturer guarantees that the value of resistance of resistor lies between 900Ω and 1100Ω .

Relative (Fractional) Limiting Error

The relative limiting error is defined as the ratio of the error to the specified (nominal) magnitude of the quantity.

Relative Limiting Error $\epsilon_r =$

Then limiting values calculated as follows,

We know that $A_a = A_n \pm \delta A = A_n \pm \epsilon_r A_n = A_n (1 \pm \epsilon_r)$

Percentage limiting error % $\epsilon_r = \epsilon_r \times 100$

In limiting errors the nominal value A_n is taken as the true value or quantity, the quantity which has the maximum deviation from A_a is taken as the incorrect quantity.

Then $\delta A = A_a - A_n$

Therefore Relative Limiting Error $\epsilon_r = \frac{A_a - A_n}{A_n} = \frac{\text{Actual value} - \text{nominal value}}{\text{nominal value}}$

For Example, considered $A_n = 100\Omega$ and $\delta A = \pm 10\Omega$;

Relative limiting error $\epsilon_r = \frac{\pm 10}{100} = \pm 0.1$

Percentage Limiting error % $\epsilon_r = 0.1 \times 100 = \pm 10\%$

Limiting values of resistance are:

$A_a = A_n (1 \pm \epsilon_r) = 100 (1 \pm 0.1) = 100 \pm 10\Omega$

STATISTICAL TREATMENT OF DATA:

Statistical Evaluation of measured data is obtained in two methods of tests as shown in below.

Multi Sample Test: In multi sample test, repeated measured data have been acquired by different instruments, different methods of measurement and different observer.

Single Sample Test: measured data have been acquired by identical conditions (same instrument, methods and observer) at different times.

Statistical Evaluation methods will give the most probable true value of measured quantity. The mathematical background statistical evaluation methods are Arithmetic Mean, Deviation Average Deviation, Standard Deviation and variance.

Arithmetic Mean

The most probable value of measured reading is the arithmetic mean of the number of reading taken. The best approximation is made when the number of readings of the same quantity is very large. Arithmetic mean or average of measured variables X is calculated by taking the sum of all readings and dividing by the number of reading

The Average is given by, $X = \frac{x_1 + x_2 + x_3 + \dots + x_n}{n} = \frac{\sum x_n}{n}$

Where, X= Arithmetic mean, x1, x2..... xn = Readings or variable or samples and n= number of readings.

Deviation (Deviation from the Average value)

The Deviation is departure of the observed reading from the arithmetic mean of the group of reading. Let the deviation of reading x1 be d1 and that of x2 be d2 ect.,

d1= x1- X

d2= x2- X

..

..

..

dn= xn- X

The algebraic sum deviation is Zero (d1+ d2+....+ dn= 0)

Average Deviation:

Average deviation defined as the average of the modulus (without respect to its sign) of the individual deviations and is given by,

$D = \frac{|x_1 - X| + |x_2 - X| + |x_3 - X| + \dots + |x_n - X|}{n} = \frac{\sum |d_n|}{n}$

Where, D= Average Deviation.

The average deviation is used to identify precision of the instruments which is used in making measurements. Highly precise instruments will give a low average deviation between readings.

Standard Deviation

Standard deviation is used to analysis random errors occurred in measurement. The standard Deviation of an infinite number of data is defined as the square root of the sum of individual deviations squared, divided by the number of readings (n).

Standard deviation is $\sqrt{\frac{1^2 + 2^2 + 3^2 + \dots + n^2}{n}}$; for $n > 20$

Standard deviation is $\sqrt{\frac{1^2 + 2^2 + 3^2 + \dots + n^2}{n} - 1}$; for n

< 20

Variance

The variance is the mean square deviation, which is the same as S.D except Square root. Variance is Just the squared standard deviation.

Variance $V = (\text{Standard deviation})^2$

Variance $V = \sigma^2 = \frac{1^2 + 2^2 + 3^2 + \dots + n^2}{n}$; for $n > 20$

Variance $V = s^2 = \frac{1^2 + 2^2 + 3^2 + \dots + n^2}{n} - 1 = \frac{1^2 + 2^2 + 3^2 + \dots + n^2}{n} - 1$; for $n < 20$

Histogram:

When a number of Multisample observations are taken experimentally there is a scatter of the data about some central value. For representing this results in the form of a *Histogram*. A histogram is also called a *frequency distribution curve*.

Example: Following table3.1 shows a set of 50 readings of length measurement. The most probable or central value of length is 100mm represented Histogram.

Length (mm)	Number of observed readings (frequency or occurrence)
99.7	1
99.8	4
99.9	12
100.0	19
100.1	10
100.2	3
100.3	1

Total number of readings =50

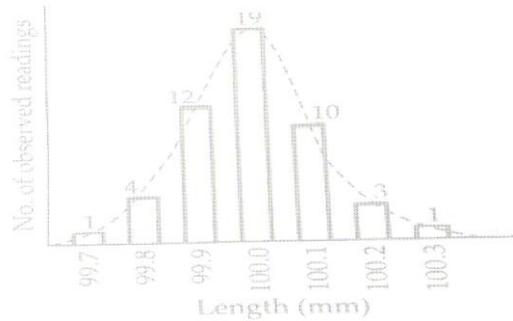

Histogram

This histogram indicates the number of occurrence of particular value. At the central value of 100mm is occurred 19 times and recorded to the nearest 0.1mm. Here bell shape dotted line curve is called as normal or Gaussian curve.

Measure of Dispersion from the Mean

The property which denotes the extent to which the values are dispersed about the central value is termed as dispersion. The other name of dispersion is *spread or scatter*.

Measure of dispersion from central value is an indication of the degree of consistency (precision) and regularity of the data.

Example: two sets of data and curve 1 vary from x_1 to x_2 and curve 2 vary from x_3 to x_4 . Curve 1 is having smaller dispersion from central value than the curve 2.

Therefore curve 1 is having greater precision than the curve 2.

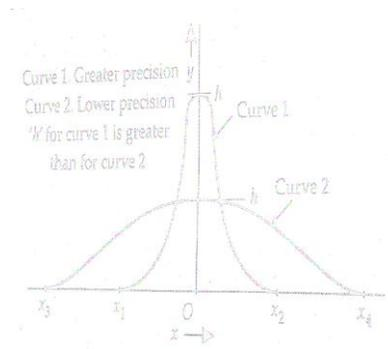

Curves showing different ranges and precision index

Range

The simplest possible measure of dispersion is the range which is the difference between greatest and least values of measured data.

Example 3.1: The set of voltage measurement that were recorded by eight different students in the laboratory as follows: 532V, 548V, 543V, 535V, 546V, 531V, 543V and 536. Calculate the Arithmetic mean, Deviations from mean, average deviation, the standard deviation and variance on recorded voltage data.

Solution:

1) Arithmetic mean

$$X = \frac{1+2+3+\dots+n}{n} = \frac{\sum x_n}{n} = \frac{532+548+543+535+546+531+543+536}{8} = \frac{4314}{8} = 539.25 \text{ V}$$

2) Deviation from mean

$$d_1 = x_1 - X = 532 - 539.25 = -7.25 \text{ V}$$

$$d_2 = x_2 - X = 548 - 539.25 = +8.75 \text{ V}$$

$$d_3 = x_3 - X = 543 - 539.25 = +3.75 \text{ V}$$

$$d_4 = x_4 - X = 535 - 539.25 = -4.25 \text{ V}$$

$$d_5 = x_5 - X = 546 - 539.25 = +6.75 \text{ V}$$

$$d_6 = x_6 - X = 531 - 539.25 = -8.25 \text{ V}$$

$$d_7 = x_7 - X = 543 - 539.25 = +3.75 \text{ V}$$

$$d_8 = x_8 - X = 536 - 539.25 = -3.25 \text{ V}$$

3) Average Deviation

$$D = \frac{|d_1| + |d_2| + |d_3| + \dots + |d_n|}{n} = \frac{\sum |d_n|}{n}$$

$$D = \frac{7.25 + 8.75 + 3.75 + 4.25 + 6.75 + 8.25 + 3.75 + 3.25}{8} = \frac{46.8}{8} = 5.85 \text{ V}$$

4) Standard Deviation (Since $n < 20$; $n = 8$)

$$s = \sqrt{\frac{1^2 + 2^2 + 3^2 + \dots + n^2}{n} - \left(\frac{1 + 2 + 3 + \dots + n}{n}\right)^2} ; \text{ For } n < 20$$

$$s = \sqrt{\dots}$$

$$(-7.25)^2 + (8.75)^2 + (3.75)^2 + (-4.25)^2 + (6.75)^2 + (-8.25)^2 + (3.75)^2 + (-3.25)^2 - 1 = 6.54 \text{ V}$$

5) Variance

$$V = s^2 = (\text{S.D})^2 = (6.54)^2 = 42.77 \text{ V}$$

Example 2: A set of 10 independent measurements were made to determine the diameter of the bob of a simple pendulum. The measured values in cm were: 1.570, 1.597, 1.562, 1.577, 1.580, 1.564, 1.586, 1.550 and 1.575. Determine the arithmetic mean, average deviation, standard deviation and the variance.

(Answer: $\bar{X}=1.575$; $D=0.011$; $\text{S.D}=s=0.0143$; $V=0.000204$;

UNIT II CHARACTERISTICS OF TRANSDUCER

STATIC CHARACTERISTICS

- Accuracy: this is a measure of the accuracy of the transducer output representing the true value being measured. It is defined as
 - $E_a = (o_t - o_m)/o_t \times 100\%$
 - Where e_a is the error, o_t is the true value being measured, o_m is the transducer or system output.
 - Accuracy is often defined in terms of a full scale output and is defined as
 - $E_s = (o_t - o_m)/o_s \times 100\%$
 - Where e_s is the full scale error, and o_s is the full scale output.
- Precision: this is a measure of the deviation from a mean value computed from a set of readings obtained for a single given input. In other words the repeatability of a transducer reading is defined by the precision specified for a specific transducer.
- Resolution: this is a measure of smallest incremented unit of the input signal that can be measured by the transducer.
- Sensitivity: the ratio of the output to the input gives a measure of a transducer system's sensitivity to a given input.
- Drift: the change in the transducer output for a zero input or its sensitivity over a period of time, change in temperature, humidity or some other factor.
- Linearity: the degree to which a given calibration curve fits a straight line within a range of the full scale output of the transducer. Linearity is often a desirable trait in instrumentation design. A transducer output may be non-linear over its entire range, but a portion of its curve over a limited range may be fairly linear; this range may be used in instrumentation design.
- Conformance: for a non-linear transducer, the tightness of fit to a specified curve is known as conformance of conformity.
- Span: the operational full scale range of the transducer is known as the span. The span is therefore defined as the difference between the maximum and minimum outputs of the transducer.
- Hysteresis: the difference in transducer output y for the same input x dependent on the manner in which the input signal x is varied.

- Distortion: the difference of the actual output from the expected result as defined by a known linear or non-linear relationship (curve) of input and output for the transducer.
- Noise: a signal generated by internal circuitry or external interference that is superimposed or added to the output signal.

The above characteristics of a transducer are generally determined by examining the output response of a transducer to various input signals. Test conditions simulate actual operating conditions as closely as possible. Standard statistical and computational methods can be applied to the test data. For further information refer to standard texts on laboratory practice and measurements.

DIFFERENCE BETWEEN SENSORS AND TRANSDUCERS

S.No	Sensor	Transducer
1.	As the term suggests, it is a body which reacts to a physical, chemical or biological condition. It senses . It	The conversion of energy from one form to another is known as Transduction. A transducer comes for this purpose
2.	A Sensor can sense in any form(usually electronic) i.e due to some mechanical change, it can react in electrical form. Thus there is a conversion, similar to that of a transducer. A classic example would be a thermocouple. Or a pressure sensor which might detect pressure and	Transducer is more than a sensor. It consists of a sensor/actuator along with signal conditioning circuits. A signal conditioning circuit, by the name is a circuit which conditions the signal so that it is strong enough for further processing. A system might contain many stages before the signal finally reaches its destination to derive meaningful information.

ACTIVE AND PASSIVE TRANSDUCERS

Passive Type Transducers

a. Resistance Variation Type

- Resistance Strain Gauge – The change in value of resistance of metal semi-conductor due to elongation or compression is known by the measurement of torque, displacement or force.
- Resistance Thermometer – The change in resistance of metal wire due to the change in temperature known by the measurement of temperature.

- Resistance Hygrometer – The change in the resistance of conductive strip due to the change of moisture content is known by the value of its corresponding humidity.
- Hot Wire Meter – The change in resistance of a heating element due to convection cooling of a flow of gas is known by its corresponding gas flow or pressure.
- Photoconductive Cell – The change in resistance of a cell due to a corresponding change in light flux is known by its corresponding light intensity.
- Thermistor – The change in resistance of a semi-conductor that has a negative co-efficient of resistance is known by its corresponding measure of temperature.
- Potentiometer Type – The change in resistance of a potentiometer reading due to the movement of the slider as a part of an external force applied is known by its corresponding pressure or displacement.

b. Capacitance Variation Type

- Variable Capacitance Pressure Gauge – The change in capacitance due to the change of distance between two parallel plates caused by an external force is known by its corresponding displacement or pressure.
- Dielectric Gauge – The change in capacitance due to a change in the dielectric is known by its corresponding liquid level or thickness.
- Capacitor Microphone – The change in capacitance due to the variation in sound pressure on a movable diaphragm is known by its corresponding sound.

c. Inductance Variation Type

- Eddy Current Transducer – The change in inductance of a coil due to the proximity of an eddy current plate is known by its corresponding displacement or thickness.
- Variable Reluctance Type – The variation in reluctance of a magnetic circuit that occurs due to the change in position of the iron core or coil is known by its corresponding displacement or pressure.
- Proximity Inductance Type – The inductance change of an alternating current excited coil due to the change in the magnetic circuit is known by its corresponding pressure or displacement.
- Differential Transformer – The change in differential voltage of 2 secondary windings of a transformer because of the change in position of the magnetic core is known by its corresponding force, pressure or displacement.

- Magnetostrictive Transducer – The change in magnetic properties due to change in pressure and stress is known by its corresponding sound value, pressure or force.

d. Voltage and Current Type

- Photo-emissive Cell – Electron emission due to light incidence on photo-emissive surface is known by its corresponding light flux value.
- Hall Effect – The voltage generated due to magnetic flux across a semi-conductor plate with a movement of current through it is known by its corresponding value of magnetic flux or current.
- Ionisation Chamber – The electron flow variation due to the ionisation of gas caused by radio-active radiation is known by its corresponding radiation value.

2. Active Type

- Photo-voltaic Cell – The voltage change that occurs across the p-n junction due to light radiation is known by its corresponding solar cell value or light intensity.
- Thermopile – The voltage change developed across a junction of two dissimilar metals is known by its corresponding value of temperature, heat or flow.
- Piezoelectric Type – When an external force is applied on to a quartz crystal, there will be a change in the voltage generated across the surface. This change is measured by its corresponding value of sound or vibration.
- Moving Coil Type – The change in voltage generated in a magnetic field can be measured using its corresponding value of vibration or velocity.

SENSOR FOR MOTION AND POSITION

MEASUREMENT: Motion Sensors

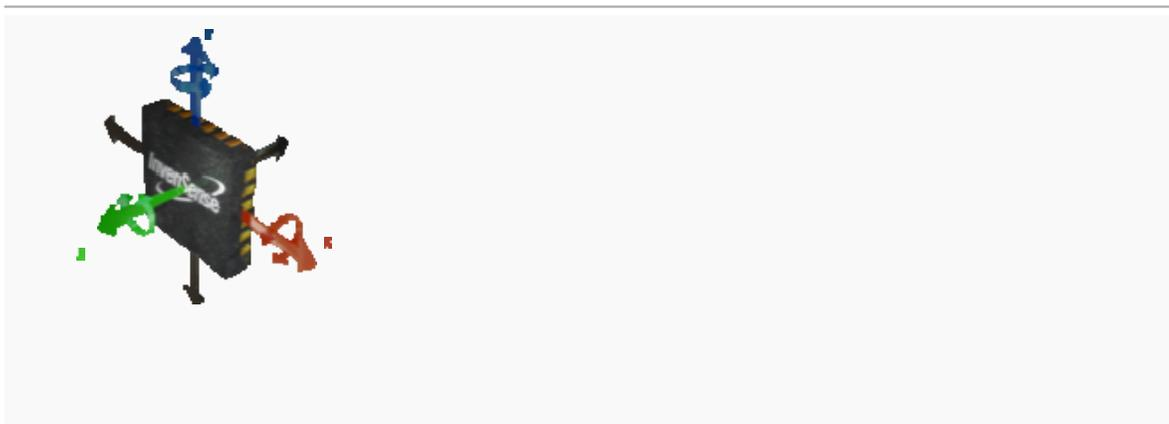

InvenSense Motion Processing

Accelerometer

s

Accelerometers measure linear acceleration and tilt angle. Single and multi-axis accelerometers detect the combined magnitude and direction of linear, rotational and gravitational acceleration. They can be used to provide limited motion sensing functionality. For example, a device with an accelerometer can detect rotation from vertical to horizontal state in a fixed location. As a result, accelerometers are primarily used for simple motion sensing applications in consumer devices such as changing the screen of a mobile device from portrait to landscape orientation. The early generation Apple iPhone and Nintendo Wii incorporated accelerometers.

Gyroscopes

Gyroscopes measure the angular rate of rotational movement about one or more axes. Gyroscopes can measure complex motion accurately in multiple dimensions, tracking the position and rotation of a moving object unlike accelerometers which can only detect the fact that an object has moved or is moving in a particular direction. Further, unlike accelerometers and compasses, gyroscopes are not affected by errors related to external environmental factors such as gravitational and magnetic fields. Hence, gyroscopes greatly enhance the motion sensing capabilities of devices and are used for advanced motion sensing applications in consumer devices such as full gesture and movement detection and simulation in video gaming. The Nintendo Wii MotionPlus accessory and the Nintendo 3DS incorporate gyroscopes.

Compass

s

Magnetic Sensors, commonly referred to as compasses detect magnetic fields and measure their absolute position relative to Earth's magnetic north and nearby magnetic materials. Information from magnetic sensors can also be used to correct errors from other sensors such as accelerometers. One example of how compass sensors are used in consumer devices is reorienting a displayed map to match up with the general direction a user is facing.

Barometer

s

Pressure Sensors, also known as barometers measure relative and absolute altitude through the analysis of changing atmospheric pressure. Pressure sensors can be used in consumer devices for sports and fitness or location-based applications where information on elevation can be valuable.

POSITION SENSORS

A position sensor is any device that permits position measurement. It can either be an absolute position sensor or a relative one (displacement sensor). Position sensors can be linear, angular, or multi-axis.

- Capacitive transducer
- Capacitive displacement sensor
- Eddy-current sensor
- Ultrasonic sensor
- Grating sensor
- Hall effect sensor
- Inductive non-contact position sensors
- Laser Doppler Vibrometer (optical)
- Linear variable differential transformer (LVDT)
- Multi-axis displacement transducer
- Photodiode array
- Piezo-electric transducer (piezo-electric)
- Potentiometer
- Proximity sensor (optical)
- Rotary encoder (angular)

GPS SATELLITE NAVIGATION SYSTEM:

The GPS system consists of three main segments:

- The space segment (all functional satellites)

- The control segment (all ground stations involved in the monitoring of the system:master control station, Monitor stations,and ground control stations)
- The user segment (all civil and military GPS users)

SPACE SEGMENT:

It consists of the system regarding GPS which are present above ground level.
It gives information about:

- a)Satellite that sends the information.
- b)Where the satellite should be at a given time(satellite location)
- c)Whether the satellite is working properly or not..?
- d)The date and time the signal is sent / received.

CONTROL SEGMENT:

The control segment is responsible for constantly monitoring the satellite health, signal integrity, orbital configuration from the ground. It consists of following sections

Master control station, Monitor stations and Ground antennas.

USER SEGMENT:

GPS user segment is the GPS receiver. The GPS receiver collects/sends the information, processes it and displays accordingly

APPLICATIONS:

- 1)Agriculture,
- 2)Aviation,
- 3)Environment,
- 4)Ground Navigation,
- 5)Marine,
- 6)Military,
- 7)Public safety,
- 8)Recreation,

9)Rail,

10)Space

11)Surveying,

12)Timing.

INERTIAL SENSORS:

To navigate we require navigation sensors. They are called as inertial sensors .
It's of two types:

1) Accelerometers
and

2)
Gyros.

Both are required for a proper navigation system. The combination of these is called as Inertial Measurement system(IMS)

THE ACCELEROMETER:

An accelerometer is a device that measures proper acceleration. Conceptually, an accelerometer behaves as a damped mass on a spring. When the accelerometer experiences acceleration, the mass is displaced to the point that the spring is able to accelerate the mass at the same rate as the casing. The displacement is then measured to give the acceleration. In commercial devices, piezoelectric, piezoresistive and capacitive components are commonly used to convert the mechanical motion into an electrical signal.

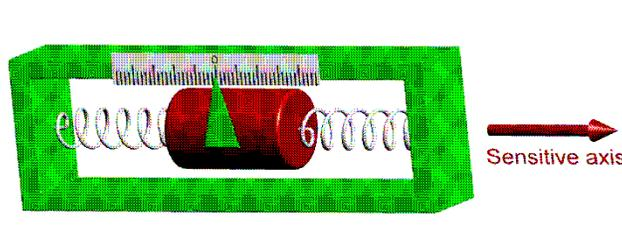

ACCELEROMETER.

Using 3 or more accelerometers we can get a 3 dimensional specific force measurement. It is denoted by f_{IB}^B

This means that specific force of the body system (B) relative inertial space (I), decomposed in the body system.

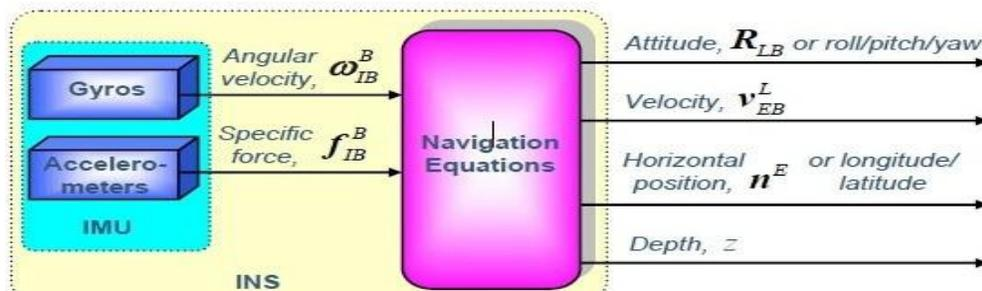

An IMU is sufficient to navigate relative to inertial space (no gravitation present), given initial values of velocity, position and attitude:

–Integrating the sensed acceleration will give velocity.

–A second integration gives position.

–To integrate in the correct direction, attitude is needed. This is obtained by integrating the sensed angular velocity.

The combination of an IMU and a computer running navigation equations is called an Inertial Navigation System (INS).

The Navigation equations can be a computer or a Microprocessor. They evaluate the position, velocity, position and altitude based upon the predefined equations stored in it.

DOPPLER EFFECT

The Doppler Effect is the change in the observed frequency of a source due to the relative motion between the source and the receiver. The relative motion that affects the observed frequency is only the motion in the Line-Of-Sight (LOS) between the source and the receiver.

Relative motion of the receiver:

If a source is stationary, as the one below, it will emit sound waves that propagate out from the source as shown below. As the receiver moves towards the source, it will detect the sound coming from the source but each successive sound wave will be detected earlier than it would have if the receiver were stationary, due to the motion of the receiver in the LOS. Thus the

frequency that each successive wave front would be detected would be changed.

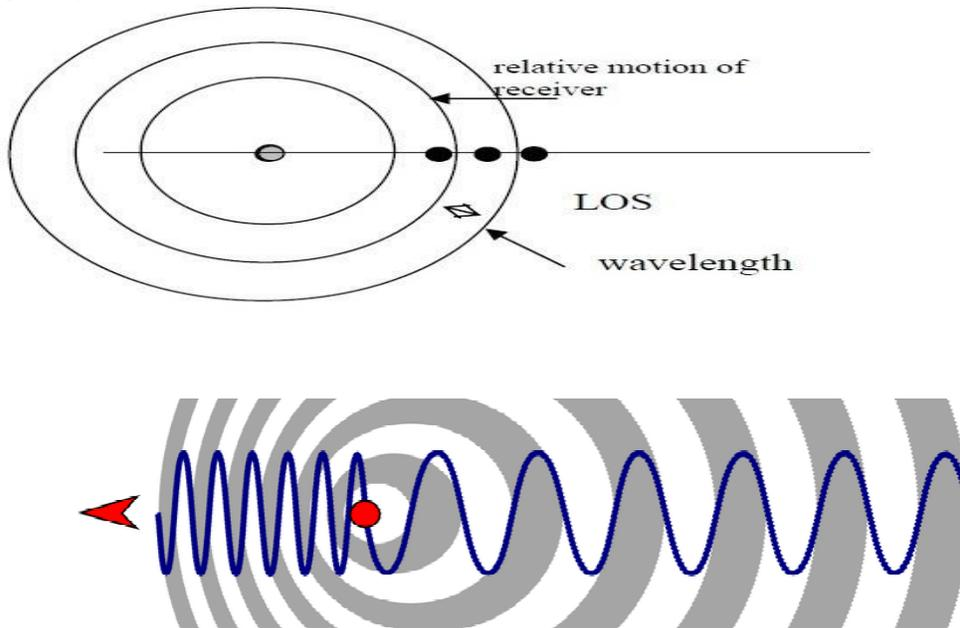

The equation is

$$\Delta f = \frac{v_r}{\lambda_0}$$

λ_0 is the original wavelength of the source

Δf is the change in the observed frequency

v_r is the velocity of the receiver in the LOS

Since the original frequency of the source can be expressed in terms of the wavelength where $f_0 = \frac{c}{\lambda_0}$, the observed frequency becomes:

$$f' = f_0 + \Delta f$$

$$f' = \frac{c}{\lambda_0} + \frac{v_r}{\lambda_0}$$

$$f' = f_0 \left(\frac{c + v_r}{c} \right)$$

Note that this equation only works if the relative velocity of the receiver, v_r is towards the source. If the motion is away from the source, the relative velocity would be in the opposite direction and the equation would become:

$$f' = f_0 \left(\frac{c - v_r}{c} \right)$$

The two equations are usually combined and expressed as:

$$f' = f_0 \left(\frac{c \pm v_r}{c} \right)$$

Relative motion of the source

If the source is moving towards the receiver, the effect is slightly different. The spacing between the successive wave fronts would be less as seen in the diagram below. This would be expressed as:

$$\Delta\lambda = \frac{v_s}{f_0}$$

v_s is the relative velocity of the source

To calculate the observed frequency:

$$f' = \frac{c}{(\lambda_0 + \Delta\lambda)}$$

$$f' = f_0 \left(\frac{c}{c - v_s} \right)$$

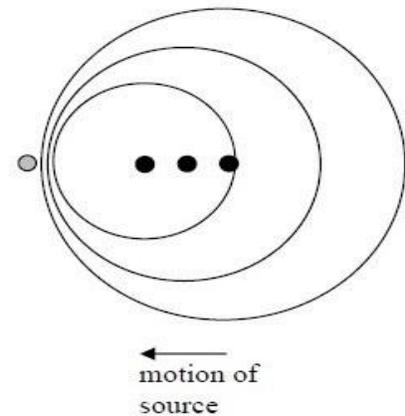

Note that this is only when the source is moving **towards** the receiver. If the source is moving away, the equation would be

$$f' = f_0 \left(\frac{c}{c + v_s} \right)$$

When combined with the previous result, the equation would be expressed as:

$$f' = f_0 \left(\frac{c}{c \mp v_s} \right)$$

Notice that this time, the plus/minus symbol is inverted because the sign on top is to be used for relative motion of the source **towards** the receiver.

Doppler Equation

By combining the previous results, we can derive one equation to use as the Doppler Equation. This is usually expressed as:

$$f' = f_0 \left(\frac{c \pm v_r}{c \mp v_s} \right)$$

The student must be careful that the quantities for the velocity of the receiver, v_r , and the velocity of the source, v_s , are only the **magnitudes** of the relative velocities **in (or along) the LOS**. In other words, the component of the velocity of the source and the receiver, that are perpendicular to the LOS do not change the received frequency. Secondly, the top sign in the numerator and the denominator are the sign convention to be used when the relative velocities are **towards** the other. If the source were moving towards the receiver, the sign to use in the denominator would be the minus sign. If the source were moving away from the receiver, the sign to use would be the plus sign.

EXAMPLE FOR DOPPLER EFFECT:



CAR siren forward the frequency is higher compared to the backward direction.

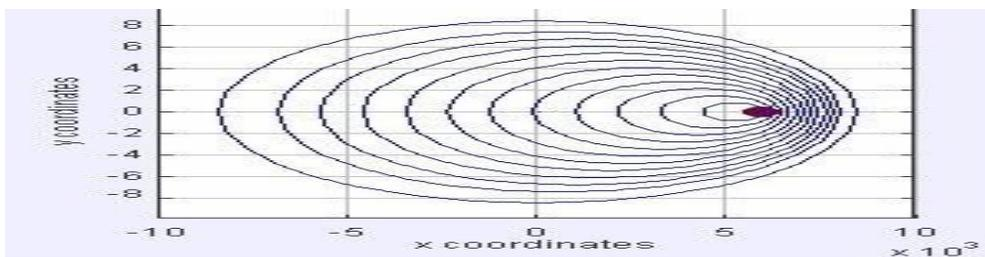

Point moving from one direction to other has frequency higher in the direction of propagation when

compared the path it followed.

SONAR (SOUND NAVIGATION AND RANGING)

Sonar (originally an acronym for(Sound Navigation And Ranging) is a technique that uses sound propagation (usually underwater, as in submarine navigation) to navigate, communicate with or detect objects on or under the surface of the water, such as other vessels. Two types of technology share the name "sonar": passive sonar is essentially listening for the sound made by vessels; active sonar is emitting pulses of sounds and listening for echoes. Sonar may be used as a means of acoustic location and of measurement of the echo characteristics of "targets" in the water. Acoustic location in air was used before the introduction of radar.

There are 4 main factors affecting the performance of a SONAR system are its components. They are

- 1)High power transmitter,
- 2)Efficient transducer sysem(actually inverse transducer),
- 3)Sensitive receiver,
- 4)Good Acoustic communication system

The speed of ultrasonic sound in water is a constant and that is 1440 meters per second.

The distance or depth of sea can be found by noting the time taken for reception of sound from the time instant it was transmitted. The formula is:

Distance(depth)=Speed of Ultrasonic sound in water x Time taken for sound for reception/ 2

Eg: if the time taken for reception of sound waves at receiver is 3 seconds then the depth is

Depth=1440 m/s x 3 s/ 2

Depth =2160 meters.

APPLICATIONS:

- 1) Torpedoes
- 2) Mines
- 3) Submarine navigation
- 4) Underwater communications
- 5) Ocean surveillance
- 6) Underwater security
- 7) Fisheries
- 8) Ship velocity measurement.as Thermometric Sensors

The response of all kind of sensors to temperature changes has always to be considered as an important influencing factor of the stability of the reading. The principle of temperature sensing is one of the most reliable transduction methods. Temperature changes can be detected simply, sensitively and reliably, and thereby also rather inexpensively. Although most enabling technologies involve either new materials or material advances, the British MNT Roadmap for gas sensors, published in 2006 [1], considers among the enabling technologies, lower cost temperature measurements as well. Therefore, the field of *thermometric gas sensing*, which is often called *calorimetric gas sensing* too, remains the subject of much research and development.

Three main categories of thermometric gas sensing have to be discussed:

- Catalytic combustion;
- Thermal conductivity;
- Adsorption/desorption heat.

7.1 Detection of Combustible Gases

Thermometric gas sensing is widely used for the indirect detection of combustible gases. The operation is based upon the measurement of temperature changes generated during burning of the flammable gaseous components in the presence of oxygen of well-known concentration, which is typically normal air. The reading is calibrated in terms of concentration of the burned gas.

completely oxidized, chemically stable products. For example, combustion of hydrogen and oxygen results simply in water vapour:

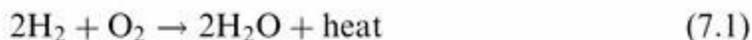

The combustion of hydrocarbons is usually more complex:

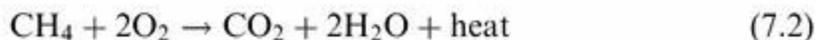

In complete combustion, when a hydrocarbon burns in oxygen, the reaction will only yield carbon dioxide and water.

In most of the *real cases oxygen is obtained from the ambient air*. Therefore, the flue gas resulting from the combustion will contain, as by far the largest part, nitrogen and the excess oxygen:

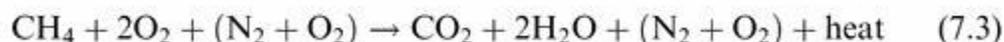

It should be noted that a complete combustion is almost impossible to achieve – *combustion processes are never perfect*. In flue gases from combustion of carbon or carbon compounds both unburned carbon (as soot) and (e.g., incompletely oxidized) carbon compounds (CO and others) will be present. In all actual combustion reactions a wide variety of major and minor species will be present.

Air is a mixture of gases, typically:

Nitrogen	77.2 %
Oxygen	20.9 %
Water Vapour	0.9 %
Argon	0.9 %
Carbon Dioxide	0.03 %
Other Gases	0.07 %

Because its composition is reasonably constant, air is usually considered as a single gas, which simplifies the measurement of flammable gases for safety applications. Moreover, when air is the oxidant, some nitrogen or even sulfuric compounds will be oxidized to various oxides (NO_x , SO_x). The above combustion of methane in air will yield, in addition to the major products of carbon dioxide and water, the minor product carbon monoxide and nitrogen oxides, which are products of a side reaction (oxidation of nitrogen).

Acoustic Temperature Sensor,

Acoustic wave sensors Acoustic wave sensors are so named because their detection mechanism is a mechanical, or acoustic, wave. As the acoustic wave propagates through or on the surface of the material, any changes to the characteristics of the propagation path affect the velocity and/or amplitude of the wave. Changes in velocity can be monitored by measuring the frequency or phase characteristics of the sensor and can then be correlated to the corresponding physical quantity being measured. Virtually all acoustic wave devices and sensors use a piezoelectric material to generate the acoustic wave. Piezoelectricity refers to the production of electrical charges by the imposition of mechanical stress. The phenomenon is reciprocal.

Applying an appropriate electrical field to a piezoelectric material creates a mechanical stress. Piezoelectric acoustic wave sensors apply an oscillating electric field to create a mechanical wave, which propagates through the substrate and is then converted back to an electric field for measurement.

Among the piezoelectric substrate materials that can be used for acoustic wave sensors and devices, the most common are quartz (SiO_2), lithium tantalate (LiTaO_3), and, to a lesser degree, lithium niobate (LiNbO_3). An interesting property of quartz is that it is possible to select the temperature dependence of the material by the cut angle and the wave propagation direction. The advantage of using acoustic waves (vs electromagnetic waves) is the slow speed of propagation (5 orders of magnitude slower). For the same frequency, therefore, the wavelength of the elastic wave is 100,000 times shorter than the corresponding electromagnetic shortwave.

This allows for the fabrication of very small sensors with frequencies into the gigahertz range with very fast response times. Solid state acoustic detectors have the electric circuit coupled to the mechanical structure where the waves propagate. The sensor generally has two (piezoelectric) transducers at each end. One at the transmitting end (generator) and one at the receiving end (receiver) where the wave is converted into an electric signal.

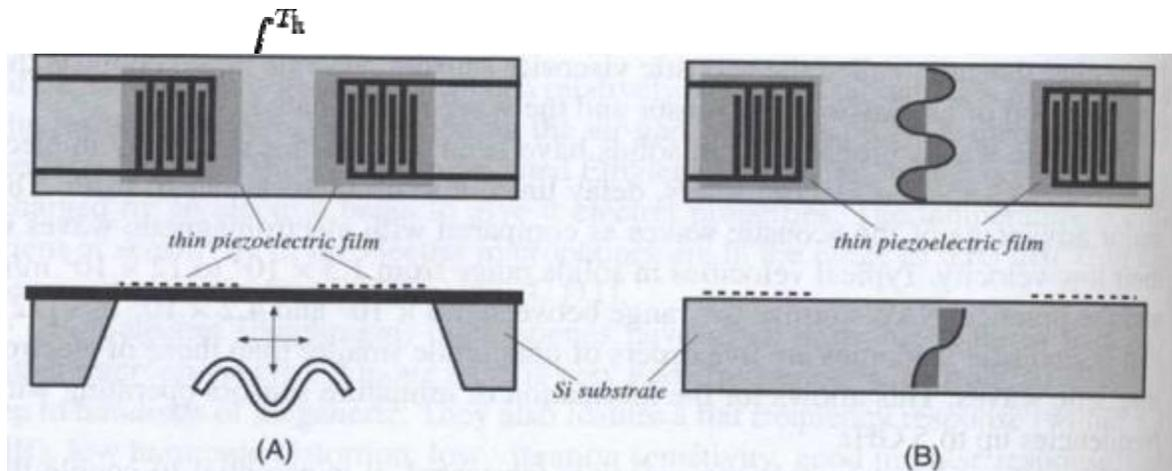
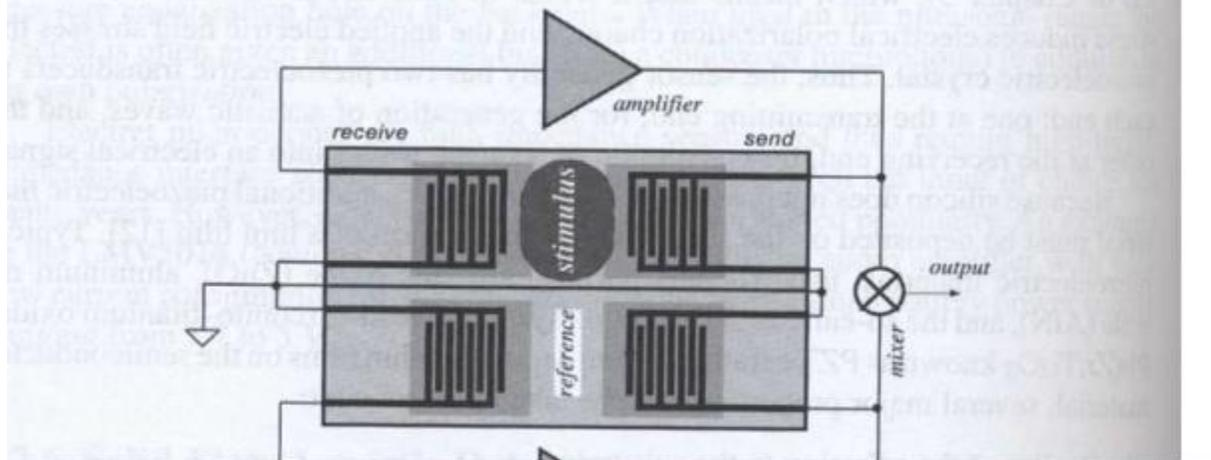

Fig. 12.7. Flexural-plate mode sensor (A) and surface acoustic wave mode (B) sensors.



On the other hand, NQR is also used to obtain detailed information on crystal symmetries and bonding, on changes in lattice constants with pressure, about phase transitions in solids, and other properties of materials of interest to solid state physicists and chemists.

As will be seen in more detail below, in order to use NQR spectroscopy one must have available an isotope with a nuclear spin $I > \frac{1}{2}$, which has a reasonably high isotopic abundance, and which is at a site in a solid that has symmetry lower than tetragonal. The most common NMR isotopes, ^1H , ^{13}C , and ^{15}N cannot be used since they have a nuclear spin $\frac{1}{2}$. Of course, ^{12}C and ^{16}O cannot be used either as they have nuclear spin 0.

Since a nuclear wavefunction has a definite state of parity, a multipole expansion of the fields due to the nucleus yields electric $2n$ -poles, where n is even (monopole, quadrupole, etc.) and magnetic $2n$ -poles, where n is odd (dipoles, octupoles, etc.). In general these multipole moments become weaker very rapidly with increasing n . In a molecule or in a solid, the nucleus will be at an equilibrium position where the electric field is zero, and so in the absence of a magnetic field the first non-zero interaction is with the electric quadrupole moment of the nucleus. Higher moments, if they exist, are generally much too weak to affect NQR measurements

A non-zero electric quadrupole moment arises for nuclei that are classically described as prolate (“stretched”) or oblate (“squashed”) spheroids. The nuclear charge distribution has axial symmetry and the axis of symmetry coincides with the direction of the nuclear angular momentum and the nuclear magnetic dipole moment. In general, an electric quadrupole moment is described by a 3×3 symmetric, traceless tensor Q .

For a nucleus such a tensor can be determined using a single value that describes how prolate or oblate the nucleus is, plus a description of the orientation of the nucleus. Since the charge distribution for a nucleus with spin 0 or $\frac{1}{2}$ is spherical, such nuclei will have no electric quadrupole moment.

If the charge distribution within the nucleus is known, the amount by which the sphere is prolate or oblate is determined by the (scalar) nuclear quadrupole moment Q , which can be calculated using where the z -axis is along the direction of axial symmetry, e is the magnitude of the charge on an electron, and U is the nuclear charge density as a function of position. While such computations may be done by a nuclear physicist to check a new model for the nucleus, the NQR spectroscopist uses values determined experimentally. Values of Q are conveniently expressed in units of $10^{-24} \text{ cm}^2 = 1 \text{ barn}$.

HEAT FLUX SENSOR

A heat flux sensor is a transducer that generates an electrical signal proportional to the total heat rate applied to the surface of the sensor. The measured heat rate is divided by the surface area of the sensor to determine the heat flux.

The heat flux can have different origins; in principle convective, radiative as well as conductive heat can be measured. Heat flux sensors are known under different names, such as heat flux transducers, heat flux gauges, heat flux plates. Some instruments that actually are single-purpose heat flux sensors like pyranometers for solar radiation measurement. Other heat flux sensors include Gardon gauges^[1] (also known as a circular-foil gauge), thin-film thermopiles,^[2] and Schmidt-Boelter gauges.^[3] In SI units, the heat rate is measured in Watts, and the heat flux is computed in Watts per meter squared.

A heat flux sensor should measure the local heat flux density in one direction. The result is expressed in watts per square meter. The calculation is done according to:

$$\phi_q = \frac{V_{sen}}{E_{sen}}$$

Where V_{sen} is the sensor output and E_{sen} is the calibration constant, specific for the sensor.

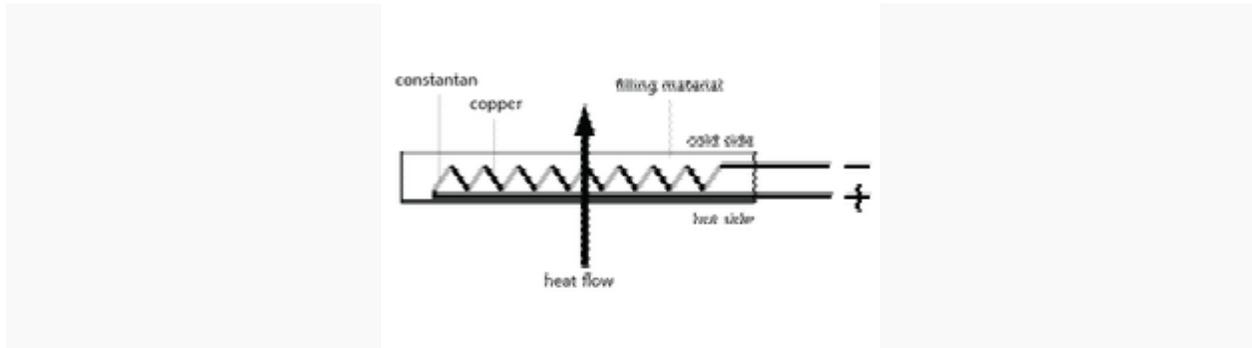

General characteristics of a heat flux sensor.

As shown before in the figure to the left, heat flux sensors generally have the shape of a flat plate and a sensitivity in the direction perpendicular to the sensor surface.

Usually a number of thermocouples connected in series called thermopiles are used. General advantages of thermopiles are their stability, low ohmic value (which implies little pickup of electromagnetic disturbances), good signal-noise ratio and the fact that zero input gives zero output. Disadvantageous is the low sensitivity.

For better understanding of heat flux sensor behaviour, it can be modeled as a simple electrical circuit consisting of a resistance, R , and a capacitor, C . In this way it can be seen that one can attribute a thermal resistance R_{sen} , a thermal capacity C_{sen} and also a response time τ_{sen} to the sensor.

Usually, the thermal resistance and the thermal capacity of the entire heat flux sensor are equal to those of the filling material. Stretching the analogy with the electric circuit further, one arrives at the following expression for the response time:

$$\tau_{sen} = R_{sen} C_{sen} = \frac{d^2 \rho C_p}{\lambda}$$

In which d is the sensor thickness, ρ the density, C_p the specific heat capacity and λ the thermal conductivity. From this formula one can conclude that material properties of the filling

material and dimensions are determining the response time. As a rule of thumb, the response time is proportional to the thickness to the power of two.

Other parameters that are determining sensor properties are the electrical characteristics of the thermocouple. The temperature dependence of the thermocouple causes the temperature dependence and the non-linearity of the heat flux sensor. The non linearity at a certain temperature is in fact the derivative of the temperature dependence at that temperature.

Sandwich construction.

To promote uniformity of sensitivity, a so-called sandwich construction as shown in the figure to the left can be used. The purpose of the plates, which have a high conductivity, is to promote the transport of heat across the whole sensitive surface.

It is difficult to quantify non-uniformity and sensitivity to lateral fluxes. Some sensors are equipped with an extra electrical lead, splitting the sensor into two parts. If during application, there is non-uniform behaviour of the sensor or the flux, this will result in different outputs of the two parts.

Summarising: The intrinsic specifications that can be attributed to heat flux sensors are thermal conductivity, total thermal resistance, heat capacity, response time, non linearity, stability, temperature dependence of sensitivity, uniformity of sensitivity and sensitivity to lateral fluxes. For the latter two specifications, a good method for quantification is not known.

UNIT 3
VARIABLE RESISTANCE TRANSDUCERS

CLASSIFICATION OF TRANSDUCER:

A sharp distinction among the types of transducers is difficult. The transducers may be classified according to their application, method of energy conversion, nature of the output signal and so on. All these classifications generally result in overlapping areas.

In one way, the electrical transducers are classified as;

- (1) Active Transducers
- (2) Passive Transducers

Active Transducers:

It is also known as self-generating type transducers. They develop their own voltage or current as the output signal. The energy required for production of this output signal is obtained from the physical phenomenon being measured.

Examples of active transducers: Thermocouple, Piezoelectric transducers, Photovoltaic cell, Moving coil generator, Photoelectric cell.

Passive Transducers:

It is also called as externally powered transducers. They derive the power required for energy conversion from an external power source.

The passive transducers are further classified into Resistive type, Inductive type and capacitive type.

Resistance:

Thermistor, Photoconductive cell, Resistance strain gauge

Inductance:

LVDT- Linear Variable Differential Transformer

Capacitance:

Photoemissive cell, Hall effect based devices.

Apart from these classifications, some kind of transducers is known as opto-electronic transducers. They use the principle of converting light energy into electrical energy. Some of the examples of opto-electronic transducers are photoconductive cell, photovoltaic cell, solar cell, photomultiplier tube and photomultiplier.

BASIC REQUIREMENTS OF THE TRANSDUCER:

Some of the basic requirements of the transducers are given below:

1. Repeatability
when the same input signal is applied to the transducer at different times under the same environmental conditions, it should give identical output signals.
2. Linearity
the transducers should have linear input-output characteristics.
3. Ruggedness
The transducer circuit should have overload protection so that it will withstand overloads.
4. High stability and reliability
the transducers output signal should not get affected by environmental variations (disturbances) like temperature, vibration etc. It should give minimum error in measurements.
5. Good dynamic response
In real-time applications, the input signal will vary with time (ie, the input signal is dynamic in nature). The transducer should respond as quick as possible for any change in the input signal
6. Convenient instrumentation
the transducers output signal should be measured either directly or after suitable amplification.
7. Mechanical characteristics
When the transducer is subjected to various mechanical strains during working conditions, its performance should not degrade. It should withstand the mechanical strains.

MECHANICAL DEVICES AS PRIMARY DETECTORS

Mechanical Devices as Primary Detectors There are a number of mechanical quantities which are to be measured. Some of these quantities are listed in Table 12.1 along with their modes of operation for the purposes of measurement. The initial concept of converting an applied force into a displacement is basic to many types of primary sensing elements. The mechanical elements which are used to convert the applied force into displacement are usually elastic members. There are many types of these elastic members. They can be classified into

three categories as: i) Direct tension or compression type ii) Bending type iii) Torsion type Table 12.1 Mechanical Quantities and their modes of operation

Type		Operation
A	Contacting spindle, pin or finger	Displacement to displacement
B	Elastic Member	
	1 Proving ring	Force to displacement
	2 Bourdon tube	Pressure to displacement
	3 Bellows	Pressure to displacement
	4 Diaphragm	Pressure to displacement
	5 Spring	Force to displacement
C	Mass	
	1 Seismic mass	Forcing function to displacement
	2 Pendulum scale	Force to displacement
	3 Manometer	Pressure to displacement
D	Thermal	
	1 Thermocouple	Temperature to electric current
	2 Bimaterial	Temperature to displacement
	3 Temp-stick	Temperature to phase

MECHANICAL SPRING DEVICES

Most mechanical-input measuring systems employ mechanical springs of one form or another. The displacements are usually small and engineering approximations for small displacements or deflections are valid. Various common types of springs are there. These range from cantilever, helical and spiral springs to torsion bars (proof) rings and spring flexure pivots.

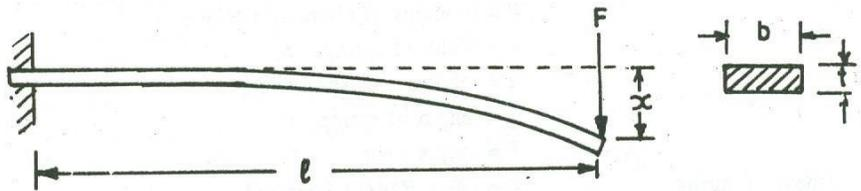
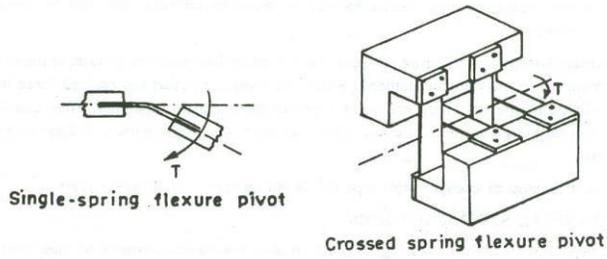
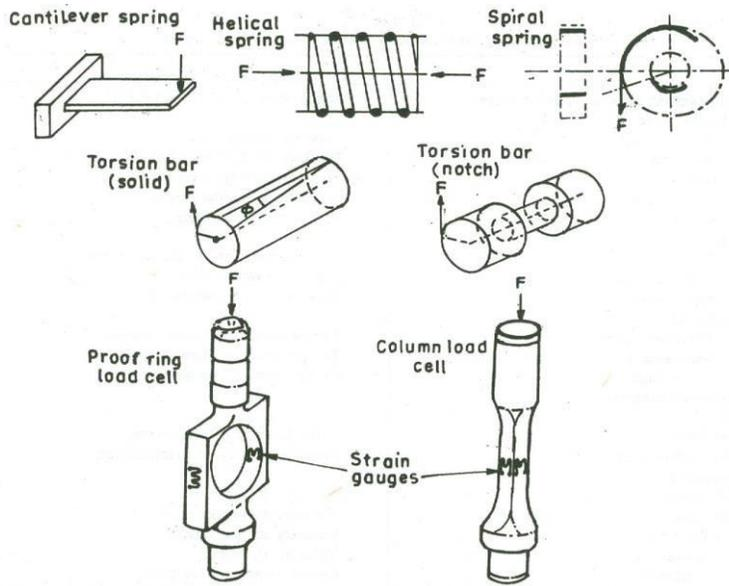

Cantilever

Deflection at the free end (x) is = $\frac{Fl^3}{3EI}$

Where

F = applied force, N

l = length of cantilever, m

E = modulus of elasticity, N/m²,

I = moment of inertia = $\left(\frac{1}{12}\right)bt^3, m^4$

b = width of cantilever, m

t = thickness of cantilever, m.

Stiffness of cantilever $K = \frac{F}{x} = 3 \frac{EI}{l^3} N / m$

Helical Spring

Fig. 3 shows a closed coiled helical spring subjected to a compressive force F .

Displacement of spring: $x = \frac{8FD^3n}{Gd^4}$

where,

F = applied force, N,

D = mean diameter of coiled spring, m

d = diameter of spring wire, m

n = number of wires

F = applied force, N,

D = mean diameter of coiled spring, m

d = diameter of spring wire, m

n = number of wires

$G = \text{shear modulus, N/m}^2$

Stiffness of spring

$$K = \frac{F}{x}$$

$$= \frac{Gd^4}{8D^3n} \text{ N/m}$$

Maximum shear stress, $\tau = 8 \frac{FD}{\pi d^3} \text{ N/m}^2$

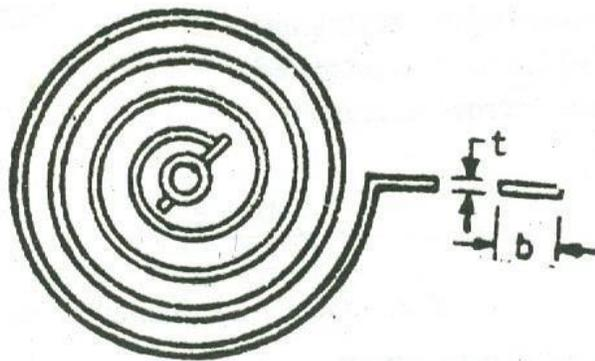
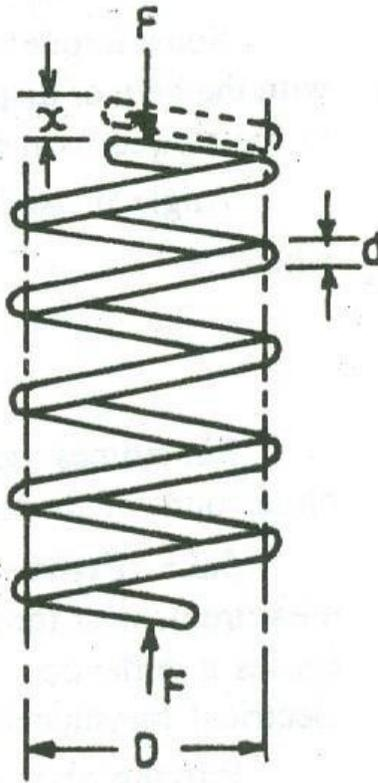

Spiral Spring

The deflection of the spring is :

$$\theta = \frac{E b t^3 T}{12 l}, \text{ rad}$$

where

E = modulus of elasticity, N/m²

b = width of spring, m

t = thickness of spring, m

l = length, of spring, m

T = torque, N-m

$$\text{Stiffness of spring } K = \frac{T}{\theta} = \frac{E b t^3}{12 l} \text{ Nm / rad}$$

The springs should be stressed well below their elastic limit at maximum deflection in order that there is no permanent set or that **no change in deflection** (or zero shift) will occur from inelastic field. Spiral springs are used for production of controlling torque in analog instruments.

PROVING (PROOF) RINGS

They are used for measurement of force, weight or load. The applied force causes deflection which is measured with the help of electrical transducers. Proving rings are made up of steel and are used as force standards. They are particularly useful for calibration of material testing machines in situations where dead weight standards are impracticable to use on account of their bulkiness. A proving ring is a circular ring or rectangular cross-section as shown in Fig. 12.5 which is subjected to either tensile or Compressive forces across its diameter.

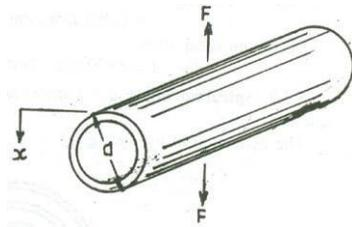

The deflection is given by: $x = \frac{(\pi/2 - 4/\pi)d^3}{16EI} F$

where

d = outside ring diameter; m.

The common practice for measurement of displacement is to attach a displacement transducer between the top and bottom of the proving ring. When the force is applied, the relative displacement can be measured. An LVDT is normally used for measurement of deflection which is of the order-of 1 mm or so. Another method is to use strain gauges for measurement of strain caused by the applied force. The strain, then, can be used to compute the applied force.

POTENTIOMETERS

POT

Resistive potentiometer used for the purposes of voltage division is called POT.

Resistive potentiometer consist of a resistive element provided with a sliding contact.

Sliding Contact-Wiper

PRINCIPLE OF OPERATION

The **translational and rotational potentiometers** which work on the basis of change in the value of resistance with change in **length** of the conductor can be used for measurement of translational or rotary displacement.

POT

It's a Passive Transducer.

Linear Pot –Translational Motion

Rotary Pot-Rotational Motion

Helipots- Combination of the two motions (translational as well as rotational).

In Electrical Measurement , Standard potentiometer are used to measure the unknown voltage by comparing it with a standard known voltage

RESISTIVE POTENTIOMETER

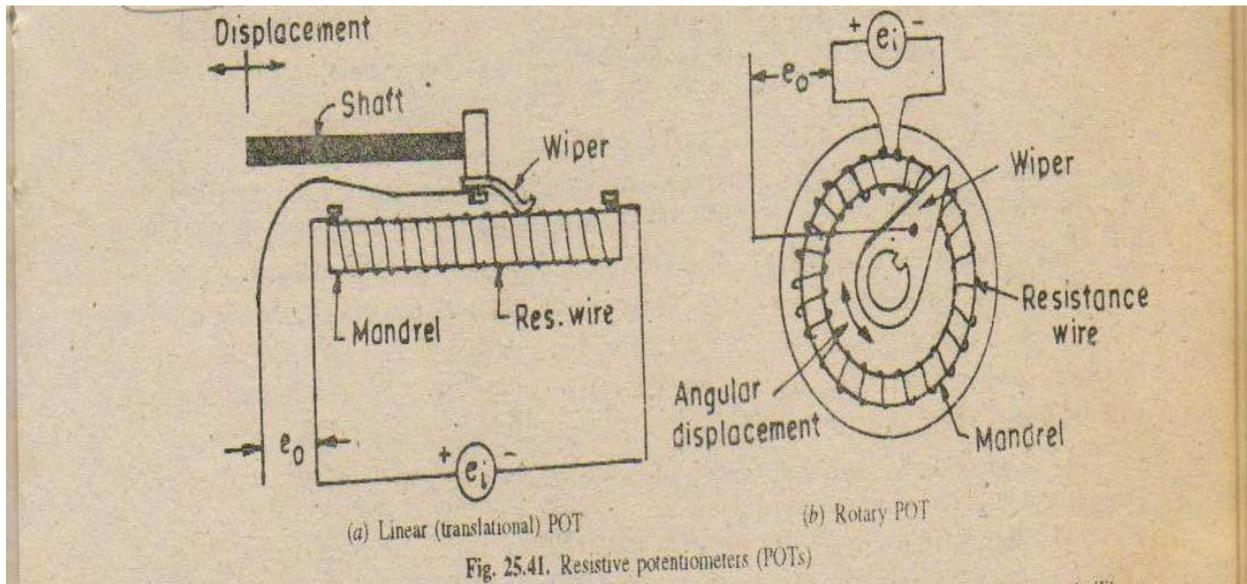

Translational, rotational and helipot

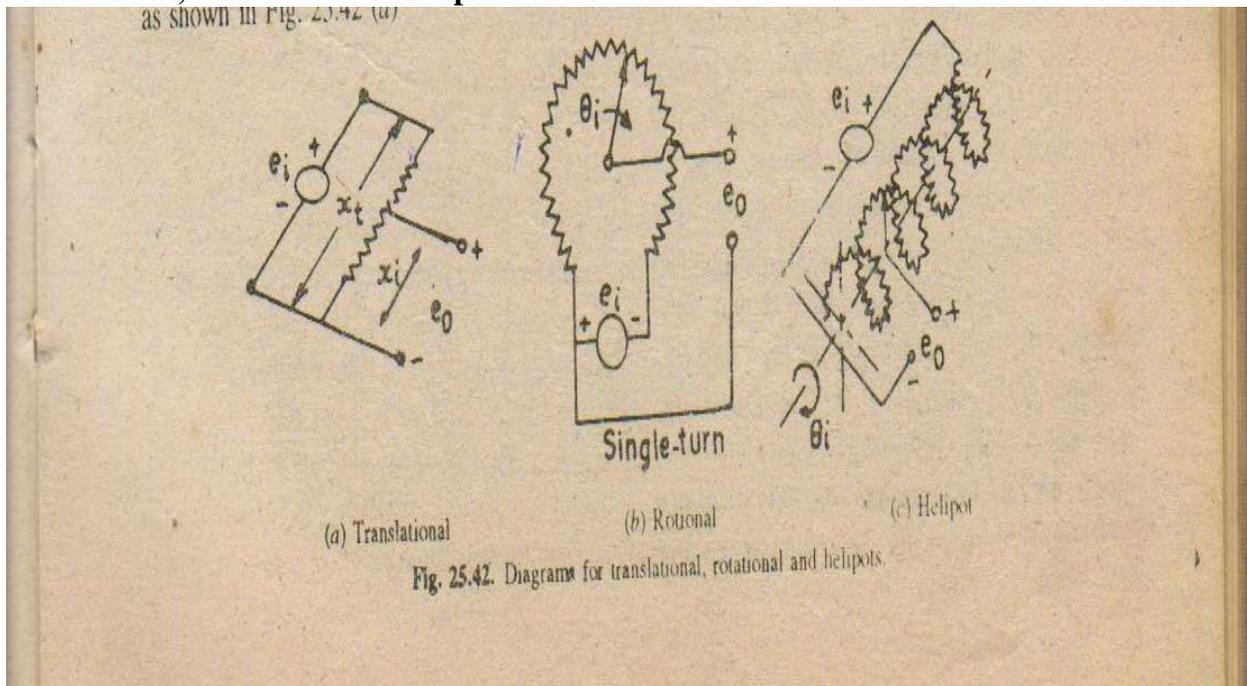

Consider a translational potentiometer

If the distribution of the resistance with respect to translational movement is linear, the resistance per length is

$$e_0 = \frac{\text{resistance at the output terminals}}{\text{resistance at the input terminals}} \times \text{input voltage}$$

$$\frac{R_p x_i / l x}{R_p} e_i = \frac{x_i}{l} \times e_i$$

For Rotational Motion

$$e_0 = \frac{i}{l} \times e_i$$

STRAIN GAUGE

When an external force is applied to an elastic material, stress is generated, which subsequently deforms the material. At this time if applied force is a tensile force, the length L of the material extends to $L + \Delta L$. The ratio of ΔL to L , that is $\Delta L/L$, is called strain. (Precisely, this is called normal strain or longitudinal strain.) On the other hand, if a compressive force is applied, the length L is reduced to $L - \Delta L$. Strain at this time is $(-\Delta L)/L$. Strain is usually represented as e .

Assuming a cross-sectional area A for the material and an applied force of P , the stress s will be P/A , since stress is defined as a force acting over a given cross sectional area. In the simple uniaxial stress field illustrated below, strain e is proportional to stress s , thus satisfying the equation $s = E \times e$, provided that the stress does not exceed the elastic limit of the material. "E" in the equation is the elastic modulus (Young's modulus) of the material.

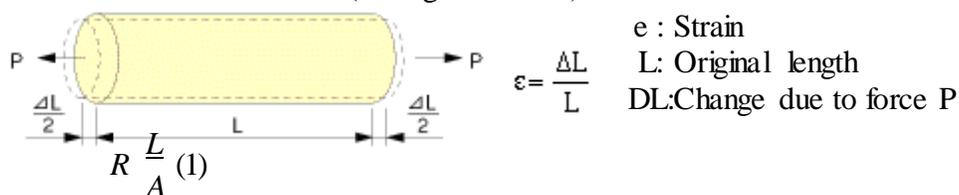

Let a tensile stress s be applied to the wire.

$$\frac{dR}{ds} = \frac{L}{A} \frac{L}{s} \frac{A}{A^2} \frac{L}{s} \frac{L}{A} \frac{L}{s} \quad -(2)$$

Divide equation (2) by

$$\frac{1}{R} \frac{dR}{ds} = \frac{1}{L} \frac{dL}{ds} - \frac{1}{A} \frac{dA}{ds} \quad - (3)$$

From (3), per unit change in resistance is due to

Per unit change in length =

Per unit change in Area =

Per unit change in resistivity =

$$\text{Area} = \frac{\pi D^2}{4} \quad \frac{dA}{A} = \frac{2 D}{D} \frac{dD}{D} \quad (4)$$

$$\frac{1}{A} \frac{dA}{ds} = \frac{(24) D}{(4) D^2} \frac{dD}{ds} = \frac{2}{D} \frac{dD}{ds} \quad (5)$$

Equation (3) can be written as

$$\frac{1}{R} \frac{dR}{ds} = \frac{1}{L} \frac{dL}{ds} - \frac{2}{D} \frac{dD}{ds} \quad - (6)$$

Poisson's ratio ,

$$\nu = \frac{\text{lateral strain}}{\text{longitudinal strain}} = \frac{dD/D}{dL/L} \quad (7)$$

or

$$dD = \nu L \frac{dL}{L} \quad (8)$$

$$\frac{1}{R} \frac{dR}{ds} = \frac{1}{L} \frac{dL}{ds} - \frac{2}{L} \frac{dL}{ds} \nu \quad - (9)$$

For small variation , the above relationship , can be written as

$$\frac{R}{L} \frac{dL}{ds} = \frac{L}{L} \frac{dL}{ds} - 2\nu \frac{L}{L} \frac{dL}{ds} \quad - (10)$$

The gauge factor is defined as the ratio of per unit change in resistance to per unit change in length.

$$G = \frac{R/R}{L/L} \quad -(11)$$

$$\text{or } R/R = G_f L L / G_f \quad (12)$$

$$\text{where strain } L / L \quad (13)$$

$$G_f = \frac{R/R}{L/L} \cdot \frac{1}{2v} \quad (12)$$

$$G_f = \frac{R/R}{L/L} \cdot \frac{1}{2v} \quad (13)$$

Types of strain gauges

- Unbonded metal strain gauge
- Bonded metal wire strain gauge
- Bonded metal foil strain gauge
- Vacuum deposited thin metal film strain gauges.
- Sputter deposited thin metal film strain gauge.
- Bonded semiconductor strain gauges.
- Diffused metal strain gauge.

Unbonded Metal Strain Gauge

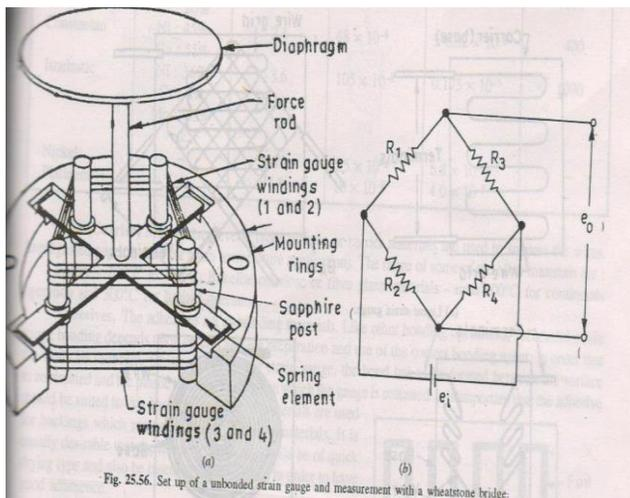

Fig. 25.56. Set up of an unbonded strain gauge and measurement with a wheatstone bridge.

Used almost exclusively in transducer applications.

At initial preload, the strains and resistances of the four arms are normally equal, with the result the output voltage of the bridge, $e_0=0$.

Application of pressure produces a small displacement, the displacement increases tension in 2 wires and decreasing the resistance of the remaining 2 wires.

This causes an unbalance of the bridge producing an output voltage which is proportional to the input displacement and hence to the applied pressure.

Bonded Metal Wire Strain Gauge

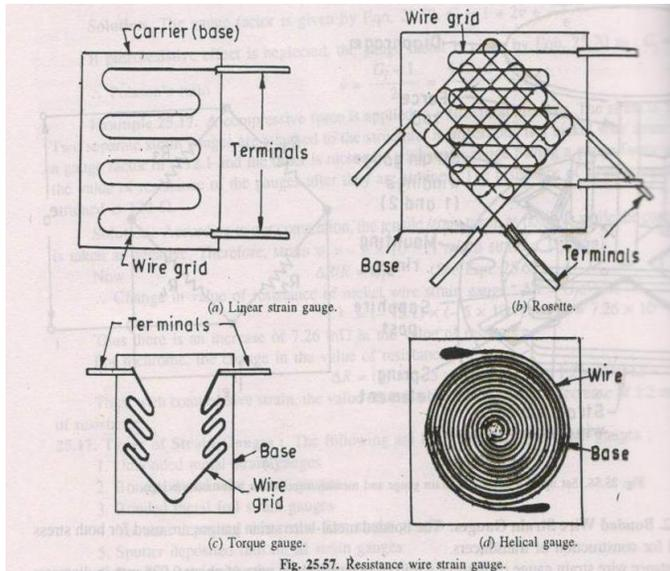

It consists of a grid of fine resistance wire of diameter of about 0.025mm.

The wire is cemented to a base.

The base – thin sheet of paper or bakelite.

Wire is covered with a thin sheet of material so that it is not damaged mechanically.

The spreading of wire permits a uniform distribution of stress over a grid.

Bonded Metal Foil Strain Gauge

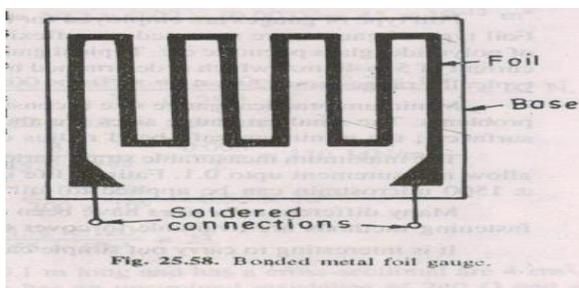

Extension of the bonded metal wire strain gauge.

The bonded metal wire strain gauge have been completely superseded by bonded foil strain gauge.

Metal Foil Strain Gauge

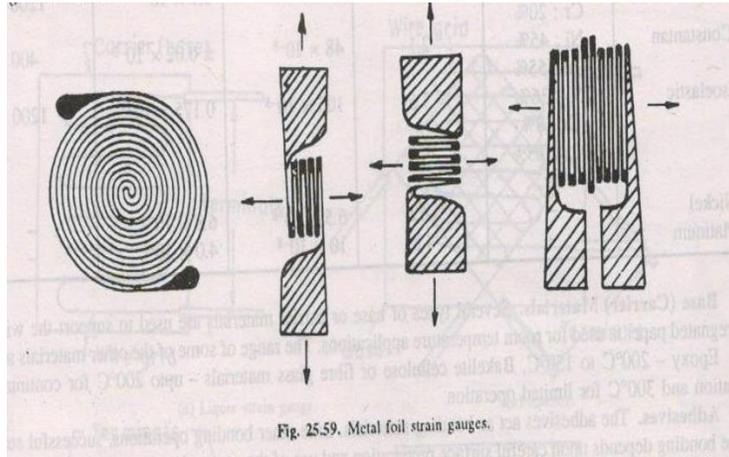

Rosettes

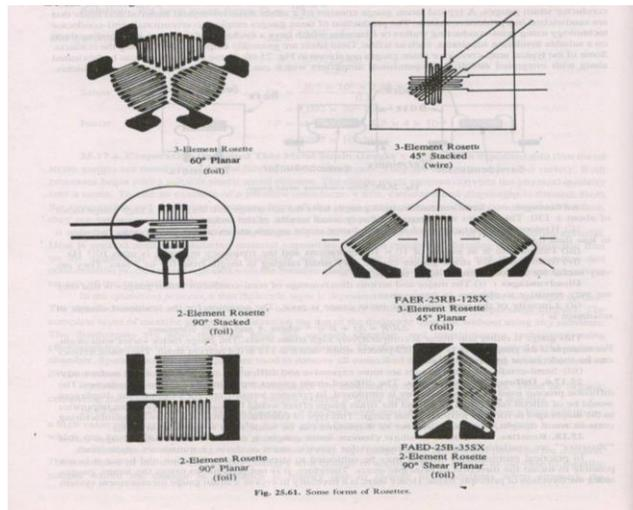

RESISTANCE HYGROMETER

Structure and principle of electronic-type polymeric humidity sensors

Polymeric humidity sensors can be broadly divided into two types: an elastic type and an electronic type.

The electronic type has two subtypes: a resistance change type and a capacitance type.

Resistance change-type humidity sensors pick up changes in the resistance value of the sensor element in response to changes in humidity, to send them as electric signals. The basic structure is shown in the model below

Basic structure of resistance change-type humidity sensors

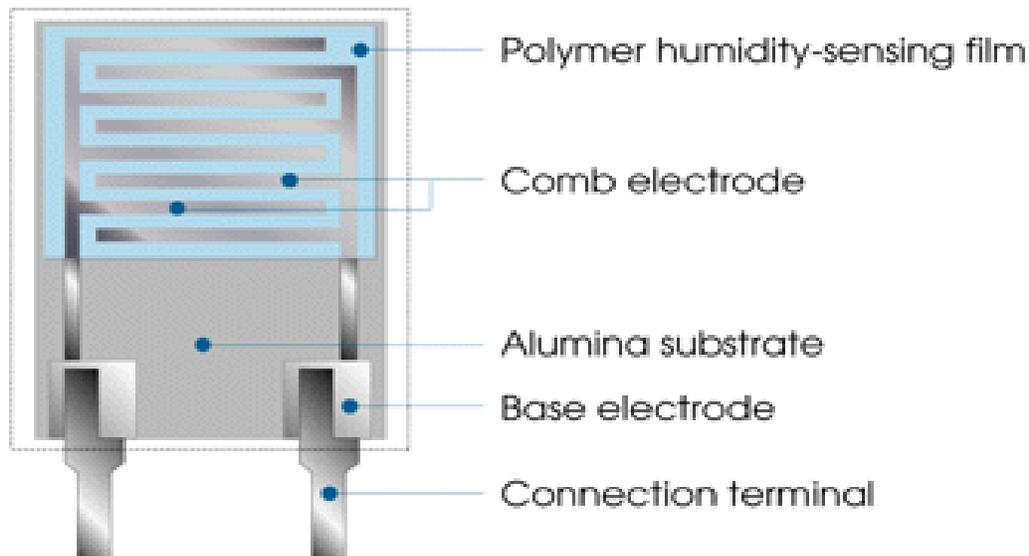

A thick film conductor made of precious metals such as gold or ruthenium oxide is printed and calcinated in the shape of a comb to form an electrode. Next, polymeric material is applied to the electrode to make a humidity-sensing film

Features of the capacitance change type and the resistance change type

- Humidity sensor elements for the capacitance change type so excel in linearity that measurement of 0%RH in relative humidity is possible.
- But they have a capacitance that runs into the hundreds of pico-farads at 0%RH, and the variable range of the capacitance at 0 to 100%RH is as low as double-digit pico-farads.
- To expand the capacitance range and at the same time to cancel out the huge zero offsets, the circuit must be so complex that high cost is involved. It also needs regular calibration.

PHOTOCONDUCTIVE CELL

The **photoconductive cell** is a two terminal semiconductor device whose terminal **resistance** will vary (linearly) with the intensity of the incident light. For obvious reasons, it is frequently called *photoresistive device*.

The photoconductive materials most frequently used include cadmium sulphide (CdS) and cadmium selenide (CdSe). Both materials respond rather slowly to changes in light intensity. The peak spectral response time of CdS units is about 100 ms and 10 ms for CdSe cells. Another important difference between the two materials is their temperature sensitivity. There is large change in the resistance of a cadmium selenide cell with changes in ambient temperature, but the resistance of cadmium sulphide remains relatively stable. The *spectral response* of a cadmium

sulphide cell closely matches that of the human eye, and the cell is therefore often used in applications where human vision is a factor, such as street light control or automatic iris control for cameras.

The essential elements of a photoconductive cell are the ceramic substrate, a layer of photoconductive material, metallic electrodes to connect the device into a circuit and a moisture resistant enclosure.

The circuit symbol and construction of a typical photoconductive cell are shown.

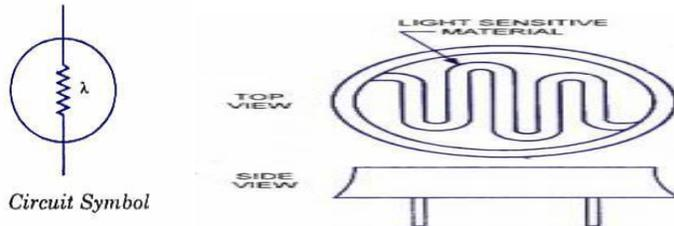
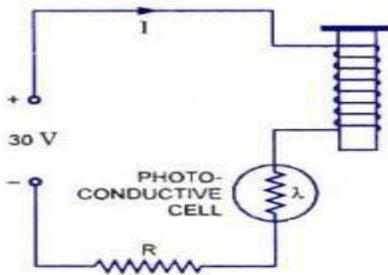

Photo-Conductive-Cell-Circuit-Symbol

Photo-Conductive-Cell-Construction

Light sensitive material is arranged in the form of a long strip, zigzagged across a disc shaped base with protective sides. For added protection, a glass or plastic cover may be included. The two ends of the strip are brought out to connecting pins below the base.

Photoconductive cell circuit:



Characteristics of a Photoconductive cell:

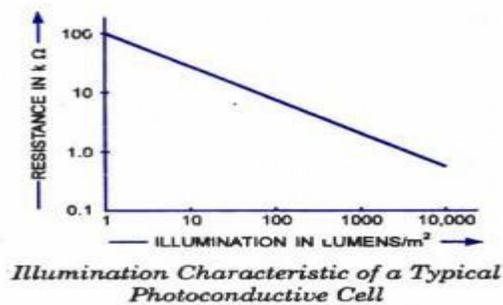

Photo-Conductive-Cell-Characteristics

The illumination characteristics of a typical photoconductive cell are shown from which it is obvious that when the cell is not illuminated its resistance may be more than 1 00 kilo ohms. This resistance is called the *dark resistance*. When the cell is illuminated, the resistance may fall to a few hundred ohms. Note that the scales on the illumination characteristic are logarithmic to cover a wide ranges of resistance and illumination that are possible. Cell sensitivity may be expressed in terms of the cell current for a given voltage and given level of illumination.

The major drawback of the photoconductive cells is that temperature variations cause substantial variations in resistance for a substantial variations in resistance for a particular light intensity. Therefore such a cell is unsuitable for analog applications.

The photoconductive cell used for relay control is shown as circuit above When the cell is illuminated, its resistance is low and the relay current is at its maximum. When the cell is dark, its high resistance reduces the current down to a level too low to energize the relay. Resistance R is included to limit the relay current to the desired level when the resistance of the cell is low. Photoconductive cells are used to switch transistors on and off, as illustrated in figure. When the cell shown in figure is dark, the transistor base is biased above its emitter level, and the device is turned on. When the cell is illuminated, the lower resistance of the cell in series with R biases the transistor base voltage below its emitter level. Thus, the device is turned off.

HOT WIRE ANEMOMETER

Constant Current Method

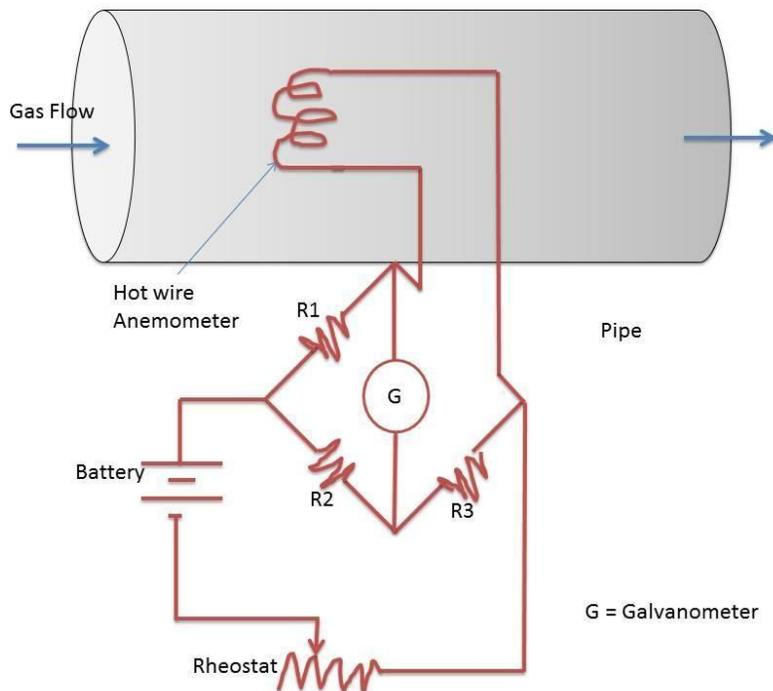

Thermal anemometry is the most common method used to measure instantaneous fluid velocity. The technique depends on the convective heat loss to the surrounding fluid from an electrically heated sensing element or probe. If only the fluid velocity varies, then the heat loss can be interpreted as a measure of that variable.

Two fundamentally different sensor types will be discussed below. Cylindrical sensors (hot wires and hot films) are most commonly used to measure the fluid velocity while flush sensors (hot films) are employed to measure the wall shear stress. Hot-wire sensors are, as the name implies, made from short lengths of resistance wire and are circular in section. Hot-film sensors consist of a thin layer of conducting material that has been deposited on a non-conducting substrate. Hot-film sensors may also be cylindrical but may also take other forms, such as those that are flush-mounted.

Thermal anemometry enjoys its popularity because the technique involves the use of very small probes that offer very high spatial resolution and excellent frequency response characteristics. The basic principles of the technique are relatively straightforward and the probes are difficult to damage if reasonable care is taken. Most sensors are operated in the constant temperature mode.

Hot-wire anemometers have been used for many years in the study of laminar, transitional and turbulent boundary layer flows and much of our current understanding of the physics of boundary layer transition has come solely from hot-wire measurements. Thermal anemometers are also ideally suited to the measurement of unsteady flows such as those that arise behind rotating blade rows when the flow is viewed in the stationary frame of reference. By a transformation of co-ordinates, the time-history of the flow behind a rotor can be converted into a pitch-wise variation in the relative frame so that it is possible to determine the structure of the rotor relative exit flow. Until the advent of laser anemometry or rotating frame instrumentation, this was the only available technique for the acquisition of rotating frame data.

Part A

- 1) What is potentiometer?
- 2) What are the advantages and disadvantages of potentiometer?
- 3) Define Active and Passive Transducers
- 4) What is gauge factor?
- 5) What are the factors to be considered for bonded strain gauge?
- 6) Define strain.
- 7) Define Humidity.
- 8) Define Mechanical Springs
- 9) What is the principle of hotwire anemometer?
- 10) Why dynamic compensation is required for hotwire anemometer?
- 11) Mention the applications of strain gauge.
- 12) What are the types of strain gauge?
- 13) Define hot wire anemometer?
- 14) Define proving rings?
- 15) Draw the diagram of hotwire anemometer

16) What are Basic Requirements of a Transducer?

Part B

1. Explain the types of strain gauges in detail with necessary diagrams
2. Explain in detail about hot-wire anemometer.
3. Explain humidity sensors in detail.
4. Explain principle of operation of a) Constant temperature type b) Constant current type of hot wire anemometer.
5. Explain the Classification of Transducers
6. Explain the Basic Requirements of a Transducer.
7. With neat diagram explain the potentiometer resistance transducer. List advantages and disadvantages.
8. Explain about the various mechanical devices used as primary detectors with neat sketch.
9. Explain temperature compensation in detail.

UNIT - IV BIOSENSORS - PHYSIOLOGICAL RECEPTORS - J RECEPTORS

A **chemoreceptor**, also known as **chemosensor**, is a specialized sensory receptor cell which transduces (responds to) a chemical substance (endogenous or induced) and generates a biological signal. This signal may be in the form of an action potential if the chemoreceptor is a neuron (nerve cell),^[1] or in the form of a neurotransmitter that can activate a nearby nerve fiber if the chemosensor is a specialized sensory receptor cell, such as the taste receptor in a taste bud^{[2][3]} or in an internal peripheral chemoreceptor such as the carotid body (ex, in chemotherapy).^[4] In more general terms, a chemosensor detects toxic or hazardous chemicals in the internal or external environment of the human body (e.x. chemotherapy) and transmits that information to the central nervous system, (and rarely the peripheral nervous system), in order to expel the biologically active toxins from the blood, and prevent further consumption of alcohol and/or other acutely toxic recreational intoxicants.

Plant chemoreceptors

Plants have various mechanisms to perceive danger in their environment. Plants are able to detect pathogens and microbes through surface level receptor kinases (PRK). Additionally, receptor-like proteins (RLPs) containing ligand binding receptor domains capture pathogen-associated molecular patterns (PAMPS) and damage-associated molecular patterns (DAMPS) which consequently initiates the plant's innate immunity for a defense response.^[5]

Plant receptor kinases are also used for growth and hormone induction among other important biochemical processes. These reactions are triggered by a series of signaling pathways which are initiated by plant chemically sensitive receptors.^[6] Plant hormone receptors can either be integrated in plant cells or situate outside the cell, in order to facilitate chemical structure and composition. There are 5 major categories of hormones that are unique to plants which once bound to the receptor, will trigger a response in target cells. These include auxin, abscisic acid, gibberellin, cytokinin, and ethylene. Once bound, hormones can induce, inhibit, or maintain function of the target response.^[7]

Classes

There are two main classes of chemoreceptor: direct and distance.^[citation needed]

- Examples of *distance chemoreceptors* are:
 - olfactory receptor neurons in the olfactory system: Olfaction involves the ability to detect chemicals in the gaseous state. In vertebrates, the olfactory system detects odors and pheromones in the nasal cavity. Within the olfactory system there are two anatomically distinct organs: the main olfactory epithelium (MOE) and the vomeronasal organ (VNO). It was initially thought that the MOE is responsible for the detection of odorants, while the VNO detects pheromones. The current view, however, is that both systems can detect odorants and pheromones.^[8] Olfaction in invertebrates differs from olfaction in vertebrates. For example, in insects, olfactory sensilla are present on their antennae.^[9]
- Examples of *direct chemoreceptors* include:
 - Taste receptors in the gustatory system: The primary use of gustation as a type of chemoreception is for the detection of tasteants. Aqueous chemical compounds come into contact with chemoreceptors in the mouth, such as taste buds on the tongue, and trigger responses. These chemical compounds can either trigger an appetitive response for nutrients, or a defensive response against toxins depending on which receptors fire. Fish and crustaceans, who are constantly in an aqueous environment, use their gustatory system to identify certain chemicals in the mixture for the purpose of localization and ingestion of food.
 - Insects use contact chemoreception to recognize certain chemicals such as cuticular hydrocarbons and chemicals specific to host plants. Contact chemoreception is more commonly seen in insects but is also involved in the mating behavior of some vertebrates. The contact chemoreceptor is specific to one type of chemical.^[9]

Sensory organs

Olfaction: In vertebrates, olfaction occurs in the Nose. Volatile chemical stimuli enter the nose and eventually reach the olfactory epithelium which houses the chemoreceptor cells known as olfactory sensory neurons often referred to as OSNs. Embedded in the olfactory epithelium are three types of cells: supporting cells, basal cells, and OSNs. While all three types of cells are

integral to normal function of the epithelium, only OSN serve as receptor cells, i.e. responding to the chemicals and generating an action potential that travels down the olfactory nerve to reach the brain.^[1] In insects, antennae act as distance chemoreceptors. For example, antennae on moths are made up of long feathery hairs that increase sensory surface area. Each long hair from the main antenna also has smaller sensilla that are used for volatile olfaction.^[10] Since moths are mainly nocturnal animals, the development of greater olfaction aids them in navigating the night.

- **Gustation:** In many vertebrates, the tongue serves as the primary gustatory sensory organ. As a muscle located in the mouth, it acts to manipulate and discern the composition of food in the initial stages of digestion. The tongue is rich in vasculature, allowing the chemoreceptors located on the top surface of the organ to transmit sensory information to the brain. Salivary glands in the mouth allow for molecules to reach chemoreceptors in an aqueous solution. The chemoreceptors of the tongue fall into two distinct superfamilies of G protein-coupled receptors. GPCR's are intramembrane proteins than bind to an extracellular ligand- in this case chemicals from food- and begin a diverse array of signaling cascades that can result in an action potential registering as input in an organism's brain. Large quantities of chemoreceptors with discrete ligand-binding domains provide for the five basic tastes: sour, salty, bitter, sweet, and savory. The salty and sour tastes work directly through the ion channels, the sweet and bitter taste work through G protein-coupled receptors, and the savory sensation is activated by glutamate.^[citation needed]
- **Contact Chemoreception:** Contact chemoreception is dependent on the physical contact of the receptor with the stimulus. The receptors are short hairs or cones that have a single pore at, or close to the tip of the projection. They are known as uniporous receptors. Some receptors are flexible, while others are rigid and do not bend with contact. They are mostly found in the mouthparts, but can also occur on the antennae or legs of some insects. There is a collection of dendrites located near the pores of the receptors, yet the distribution of these dendrites changes depending on the organism being examined. The method of transduction of the signal from the dendrites differs depending on the organism and the chemical it is responding to.
- **Cellular antennae:** Within the biological and medical disciplines, recent discoveries have noted that *primary cilia* in many types of cells within eukaryotes serve as *cellular antennae*.

These cilia play important roles in chemosensation. The current scientific understanding of primary cilia organelles views them as "sensory cellular antennae that coordinate a large number of cellular signaling pathways, sometimes coupling the signaling to ciliary motility or alternatively to cell division and differentiation."^[11]

When inputs from the environment are significant to the survival of the organism, the input must be detected. As all life processes are ultimately based on chemistry it is natural that detection and passing on of the external input will involve chemical events. The chemistry of the environment is, of course, relevant to survival, and detection of chemical input from the outside may well articulate directly with cell chemicals.^[citation needed]

Chemoreception is important for the detection of food, habitat, conspecifics including mates, and predators. For example, the emissions of a predator's food source, such as odors or pheromones, may be in the air or on a surface where the food source has been. Cells in the head, usually the air passages or mouth, have chemical receptors on their surface that change when in contact with the emissions. It passes in either chemical or electrochemical form to the central processor, the brain or spinal cord. The resulting output from the CNS (central nervous system) makes body actions that will engage the food and enhance survival.^[citation needed]

Physiology

Carotid bodies and aortic bodies detect changes primarily in oxygen. They also sense increases in CO₂ partial pressure and decreases in arterial pH, but to a lesser degree than for O₂.

-
- The chemoreceptor trigger zone is an area of the medulla in the brain that receives inputs from blood-borne drugs or hormones, and communicates with the vomiting center to induce vomiting.^[citation needed]

Control of breathing

Particular chemoreceptors, called ASICs, detect the levels of carbon dioxide in the blood. To do this, they monitor the concentration of hydrogen ions in the blood, which decrease the pH of the blood. This can be a direct consequence of an increase in carbon dioxide concentration, because aqueous carbon dioxide in the presence of carbonic anhydrase reacts to form a proton and a bicarbonate ion.^[citation needed]

The response is that the respiratory centre (in the medulla), sends nervous impulses to the external intercostal muscles and the diaphragm, via the intercostal nerve and the phrenic nerve, respectively, to increase breathing rate and the volume of the lungs during inhalation.

Chemoreceptors that regulate the depth and rhythm of breathing are broken down into two categories.^[citation needed]

- central chemoreceptors are located on the ventrolateral surface of medulla oblongata and detect changes in pH of cerebrospinal fluid. They have also been shown experimentally to respond to hypercapnic hypoxia (elevated CO₂, decreased O₂), and eventually desensitize^[citation needed]. These are sensitive to pH and CO₂.^[citation needed]
- peripheral chemoreceptors: consists of aortic and carotid bodies. Aortic body detects changes in blood oxygen and carbon dioxide, but not pH, while carotid body detects all three. They do not desensitize. Their effect on breathing rate is less than that of the central chemoreceptors.^[citation needed]

Heart rate

The response to stimulation of chemoreceptors on the heart rate is complicated. Chemoreceptors in the heart or nearby large arteries as well as chemoreceptors in the lungs can affect heart rate. Activation of these peripheral chemoreceptors from sensing decreased O₂, increased CO₂ and a decreased pH is relayed to cardiac centers by the vagus and glossopharyngeal nerves to the medulla of the brainstem. This increases the sympathetic nervous stimulation on the heart and a corresponding increase in heart rate and contractility in most cases.^[12] These factors include activation of stretch receptors due to increased ventilation and the release of circulating catecholamines.

However, if respiratory activity is arrested (e.g. in a patient with a high cervical spinal cord injury), then the primary cardiac reflex to transient hypercapnia and hypoxia is a profound bradycardia and coronary vasodilation through vagal stimulation and systemic vasoconstriction by sympathetic stimulation.^[13] In normal cases, if there is reflexive increase in respiratory activity in response to chemoreceptor activation, the increased sympathetic activity on the cardiovascular system would act to increase heart rate and contractility.

Baroreceptor

Baroreceptors (or archaically, **pressoreceptors**) are sensors located in the blood vessels of all vertebrate animals. They sense the blood pressure and relay the information to the brain, so that a proper blood pressure can be maintained.

Baroreceptors are a type of mechanoreceptor sensory neuron that are excited by a stretch of the blood vessel. Thus, increases in the pressure of blood vessel triggers increased action potential generation rates and provides information to the central nervous system. This sensory information is used primarily in autonomic reflexes that in turn influence the heart cardiac output and vascular smooth muscle to influence total peripheral resistance.^[1] Baroreceptors act immediately as part of a negative feedback system called the baroreflex,^[2] as soon as there is a change from the usual mean arterial blood pressure, returning the pressure toward a normal level. These reflexes help regulate short-term blood pressure. The solitary nucleus in the medulla oblongata of the brain recognizes changes in the firing rate of action potentials from the baroreceptors, and influences cardiac output and systemic vascular resistance.

Baroreceptors can be divided into two categories based on the type of blood vessel in which they are located: high-pressure arterial baroreceptors and low-pressure baroreceptors (also known as cardiopulmonary^[3] or volume receptors^[4]).

Arterial baroreceptors

Arterial baroreceptors are stretch receptors that are stimulated by distortion of the arterial wall when pressure changes. The baroreceptors can identify the changes in both the average blood pressure or the rate of change in pressure with each arterial pulse. Action potentials triggered in the baroreceptor ending are then directly conducted to the brainstem where central terminations (synapses) transmit this information to neurons within the solitary nucleus. Reflex responses from such baroreceptor activity can trigger increases or decreases in the heart rate. Arterial baroreceptor sensory endings are simple, splayed nerve endings that lie in the tunica adventitia of the artery. An increase in the mean arterial pressure increases depolarization of these sensory endings, which results in action potentials. These action potentials are conducted to the solitary nucleus in the central nervous system by axons and have a reflex effect on the cardiovascular

system through autonomic neurons.^[5] Hormone secretions that target the heart and blood vessels are affected by the stimulation of baroreceptors.

At normal resting blood pressures, baroreceptors discharge with each heart beat. If blood pressure falls, such as on orthostatic hypotension or in hypovolaemic shock, baroreceptor firing rate decreases and baroreceptor reflexes act to help restore blood pressure by increasing heart rate. Signals from the carotid baroreceptors are sent via the glossopharyngeal nerve (cranial nerve IX). Signals from the aortic baroreceptors travel through the vagus nerve (cranial nerve X).^[6] Arterial baroreceptors inform reflexes about arterial blood pressure but other stretch receptors in the large veins and right atrium convey information about the low pressure parts of the circulatory system.

Baroreceptors respond very quickly to maintain a stable blood pressure, but their responses diminish with time and thus are most effective for conveying short term changes in blood pressure. In people with essential hypertension the baroreceptors and their reflexes change and function to maintain the elevated blood pressure as if normal. The receptors then become less sensitive to change.^[7]

Low-pressure baroreceptors]

The low-pressure baroreceptors, are found in large systemic veins, in pulmonary vessels, and in the walls of the right atrium and ventricles of the heart (the atrial volume receptors).^[4] The low-pressure baroreceptors are involved with the regulation of blood volume. The blood volume determines the mean pressure throughout the system, in particular in the venous side where most of the blood is held.

The low-pressure baroreceptors have both circulatory and renal effects; they produce changes in hormone secretion, resulting in profound effects on the retention of salt and water; they also influence intake of salt and water. The renal effects allow the receptors to change the mean pressure in the system in the long term.

Denervating these receptors 'fools' the body into thinking that it has too low blood volume and initiates mechanisms that retain fluid and so push up the blood pressure to a higher level than it would otherwise have.

Baroreceptor dysfunction

Baroreceptors are integral to the body's function: Pressure changes in the blood vessels would not be detected as quickly in the absence of baroreceptors. When baroreceptors are not working, blood pressure continues to increase, but, within an hour, the blood pressure returns to normal as other blood pressure regulatory systems take over.^[8]

Baroreceptors can also become oversensitive in some people (usually the carotid baroreceptors in older males). This can lead to bradycardia, dizziness and fainting (syncope) from touching the neck (often whilst shaving). This is an important cause to exclude in men having pre-syncope or syncope symptoms.

Cutaneous receptor

The **cutaneous receptors** are the types of sensory receptor found in the dermis or epidermis. They are a part of the somatosensory system. Cutaneous receptors include cutaneous mechanoreceptors, nociceptors (pain) and thermoreceptors (temperature).^[1]

Types

The sensory receptors in the skin are:

- **cutaneous mechanoreceptors**
 - Ruffini's end organ (skin stretch)
 - End-bulbs of Krause (Cold)
 - Meissner's corpuscle (changes in texture, slow vibrations)
 - Pacinian corpuscle (deep pressure, fast vibrations)
 - Merkel's disc (sustained touch and pressure)
 - Free nerve endings
 - thermoreceptor
 - nociceptor
 - bulboid corpuscles(end bulbs of Krause receptor)
 - chemoreceptor
-

Modalities

With the above-mentioned receptor types the skin can sense the modalities touch, pressure, vibration, temperature and pain. The modalities and their receptors are partly overlapping, and are innervated by different kinds of fiber types.

Cutaneous receptors		
Modality	Type	Fiber type
Touch	Rapidly adapting cutaneous mechanoreceptors (Meissner corpuscle end-organs Pacinian corpuscle end-organs hair follicle receptors some free nerve endings)	A β fibers
Touch & pressure	Slowly adapting cutaneous mechanoreceptors (Merkel and Ruffini corpuscle end-organs some free nerve endings)	A β fibers (Merkel and Ruffini's), A δ fibers (free nerve endings)
Vibration	Meissners and Pacinian corpuscle end-organs	A β fibers
Temperature	Thermoreceptors	A δ fibers (cold receptors) C fibers (warmth receptors)
Pain & Itch	Free nerve ending nociceptors	A δ fibers (Nociceptors of neospinothalamic tract)

		C fibers (Nociceptors of paleospinothalamic tract)
--	--	--

Morphology

Cutaneous receptors are at the ends of afferent neurons. They are usually encapsulated in elaborate cellular corpuscles. Generally, they are linked to collagen - fibres networks within the capsule. Ion channels are situated near these networks.

In sensory transduction, the afferent nerves transmit through a series of synapses in the central nervous system, first in the spinal cord or trigeminal nucleus, depending on the dermatomic area concerned. One pathway then proceeds to the ventrobasal portion of the thalamus, and then on to the somatosensory cortex.^[2]

Biosensors: Features, Principle and Types (With Diagram)

Article Shared by Nandkishor Jha

ADVERTISEMENTS:

Read this article to learn about the features, principle and types of biosensors.

A biosensor is an analytical device containing an immobilized biological material (enzyme, antibody, nucleic acid, hormone, organelle or whole cell) which can specifically interact with an analyte and produce physical, chemical or electrical signals that can be measured. An analyte is a compound (e.g. glucose, urea, drug, pesticide) whose concentration has to be measured.

Biosensors basically involve the quantitative analysis of various substances by converting their biological actions into measurable signals. A great majority of biosensors have immobilized enzymes. The performance of the biosensors is mostly dependent on the specificity and sensitivity of the biological reaction, besides the stability of the enzyme.

General Features of Biosensors:

A biosensor has two distinct components (Fig. 21.13).

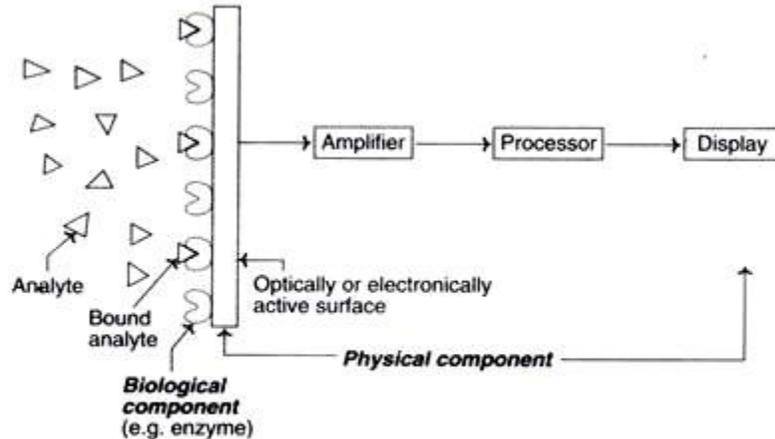

Fig. 21.13 : A diagrammatic representation of a biosensor.

1. Biological component—enzyme, cell etc.
2. Physical component—transducer, amplifier etc.

The biological component recognises and interacts with the analyte to produce a physical change (a signal) that can be detected, by the transducer. In practice, the biological material is appropriately immobilized on to the transducer and the so prepared biosensors can be repeatedly used several times (may be around 10,000 times) for a long period (many months).

Principle of a Biosensor:

The desired biological material (usually a specific enzyme) is immobilized by conventional methods (physical or membrane entrapment, non- covalent or covalent binding). This immobilized biological material is in intimate contact with the transducer. The analyte binds to the biological material to form a bound analyte which in turn produces the electronic response that can be measured.

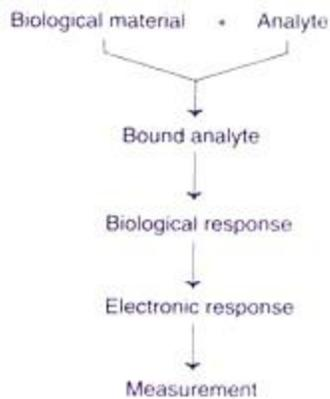

In some instances, the analyte is converted to a product which may be associated with the release of heat, gas (oxygen), electrons or hydrogen ions. The transducer can convert the product linked changes into electrical signals which can be amplified and measured.

Types of Biosensors:

There are several types of biosensors based on the sensor devices and the type of biological materials used. A selected few of them are discussed below.

Electrochemical Biosensors:

Electrochemical biosensors are simple devices based on the measurements of electric current, ionic or conductance changes carried out by bio electrodes.

Amperometric Biosensors:

These biosensors are based on the movement of electrons (i.e. determination of electric current) as a result of enzyme-catalysed redox reactions. Normally, a constant voltage passes between the electrodes which can be determined. In an enzymatic reaction that occurs, the substrate or product can transfer an electron with the electrode surface to be oxidised or reduced (Fig. 21.14).

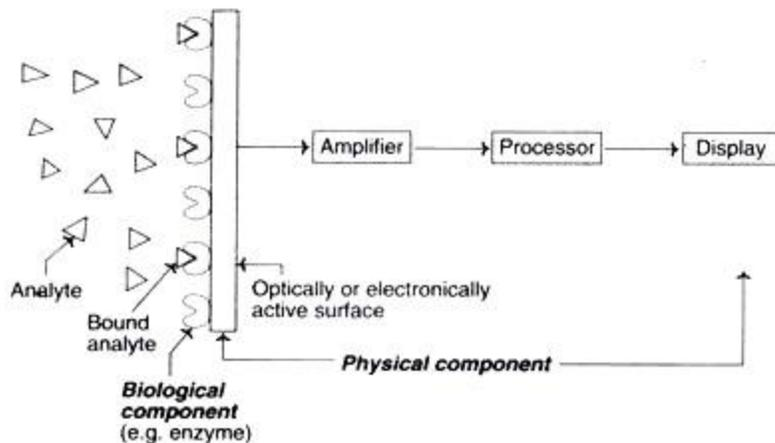

Fig. 21.13 : A diagrammatic representation of a biosensor.

This results in an altered current flow that can be measured. The magnitude of the current is proportional to the substrate concentration. Clark oxygen electrode which determines reduction of O_2 , is the simplest form of amperometric biosensor. Determination of glucose by glucose oxidase is a good example.

In the first generation amperometric biosensors (described above), there is a direct transfer of the electrons released to the electrode which may pose some practical difficulties. A second generation amperometric biosensors have been developed wherein a mediator (e.g. ferrocenes) takes up the electrons and then transfers them to electrode. These biosensors however, are yet to become popular.

ADVERTISEMENTS:

Blood-glucose biosensor:

It is a good example of amperometric biosensors, widely used throughout the world by diabetic patients. Blood- glucose biosensor looks like a watch pen and has a single use disposable electrode (consisting of a Ag/AgCl reference electrode and a carbon working electrode) with glucose oxidase and a derivative of ferrocene (as a mediator). The electrodes are covered with hydrophilic mesh gauze for even spreading of a blood drop. The disposable test strips, sealed in aluminium foil have a shelf-life of around six months.

An amperometric biosensor for assessing the freshness of fish has been developed. The accumulation of inosine and hypoxanthine in relation to the other nucleotides indicates freshness of fish-how long dead and stored. A biosensor utilizing immobilized nucleoside phosphorylase and xanthine oxidase over an electrode has been developed for this purpose.

Potentiometric Biosensors:

In these biosensors, changes in ionic concentrations are determined by use of ion- selective electrodes (Fig. 21.15). pH electrode is the most commonly used ion-selective electrode, since many enzymatic reactions involve the release or absorption of hydrogen ions. The other important electrodes are ammonia-selective and CO₂ selective electrodes.

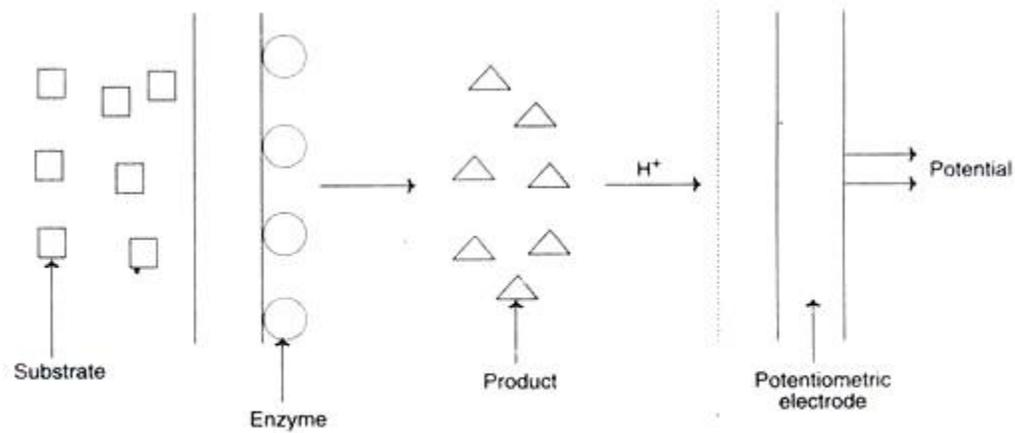

Fig. 21.15 : A diagrammatic representation of a potentiometric biosensor.

The potential difference obtained between the potentiometric electrode and the reference electrode can be measured. It is proportional to the concentration of the substrate. The major limitation of potentiometric biosensors is the sensitivity of enzymes to ionic concentrations such as H⁺ and NH₄⁺.

Ion-selective field effect transistors (ISFET) are the low cost devices that can be used for miniaturization of potentiometric biosensors. A good example is an ISFET biosensor used to monitor intra-myocardial pH during open-heart surgery.

Conduct Metric Biosensors:

There are several reactions in the biological systems that bring about changes in the ionic species. These ionic species alter the electrical conductivity which can be measured. A good

example of conduct metric biosensor is the urea biosensor utilizing immobilized urease. Urease catalyses the following reaction.



The above reaction is associated with drastic alteration in ionic concentration which can be used for monitoring urea concentration. In fact, urea biosensors are very successfully used during dialysis and renal surgery.

Thermometric Biosensors:

Several biological reactions are associated with the production of heat and this forms the basis of thermometric biosensors. They are more commonly referred to as thermal biosensors or calorimetric biosensors. A diagrammatic representation of a thermal biosensor is depicted in Fig. 21.16. It consists of a heat insulated box fitted with heat exchanger (aluminium cylinder).

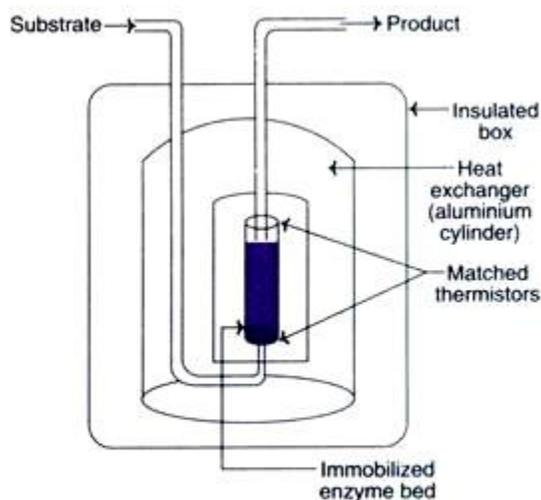

Fig. 21.16 : A diagrammatic representation of thermometric biosensor.

The reaction takes place in a small enzyme packed bed reactor. As the substrate enters the bed, it gets converted to a product and heat is generated. The difference in the temperature between the substrate and product is measured by thermistors. Even a small change in the temperature can be detected by thermal biosensors.

Thermometric biosensors are in use for the estimation of serum cholesterol. When cholesterol gets oxidized by the enzyme cholesterol oxidase, heat is generated which can be measured. Likewise, estimations of glucose (enzyme-glucose oxidase), urea (enzyme-urease), uric acid (enzyme-uricase) and penicillin G (enzyme-P lactamase) can be done by these biosensors. In general, their utility is however, limited. Thermometric biosensors can be used as a part of enzyme-linked immunoassay (ELISA) and the new technique is referred to as thermometric ELISA (TELISA).

Optical Biosensors:

Optical biosensors are the devices that utilize the principle of optical measurements (absorbance, fluorescence, chemiluminescence etc.). They employ the use of fibre optics and optoelectronic transducers. The word optrode, representing a condensation of the words optical and electrode is commonly used. Optical biosensors primarily involve enzymes and antibodies as the transducing elements. Optical biosensors allow a safe non-electrical remote sensing of materials. Another advantage is that these biosensors usually do not require reference sensors, as the comparative signal can be generated using the same source of light as the sampling sensor. Some of the important optical biosensors are briefly described hereunder.

Fibre optic lactate biosensor:

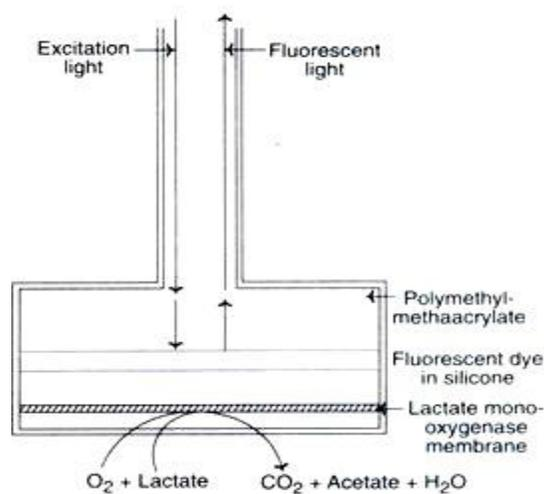
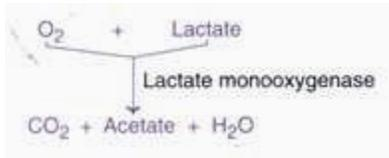

Fig. 21.17 : Diagrammatic representation of a fibre optic lactate biosensor.

Fig. 21.17 represents the fibre optic lactate biosensor. Its working is based on the measurement of changes in molecular O₂ concentration by determining the quenching effect of O₂ on a fluorescent dye. The following reaction is catalysed by the enzyme lactate mono-oxygenase.



The amount of fluorescence generated by the dyed film is dependent on the O₂. This is because O₂ has a quenching (reducing) effect on the fluorescence. As the concentration of lactate in the reaction mixture increases, O₂ is utilized, and consequently there is a proportionate decrease in the quenching effect. The result is that there is an increase in the fluorescent output which can be measured.

Optical Biosensors for Blood Glucose:

Estimation of blood glucose is very important for monitoring of diabetes. A simple technique involving paper strips impregnated with reagents is used for this purpose. The strips contain glucose oxidase, horse radish peroxidase and a chromogen (e.g. toluidine). The following reactions occur.

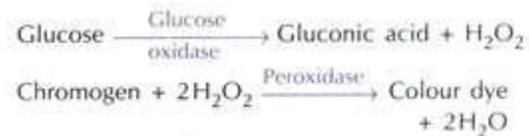

The intensity of the colour of the dye can be measured by using a portable reflectance meter. Glucose strip production is a very big industry worldwide.

Colorimetric test strips of cellulose coated with appropriate enzymes and reagents are in use for the estimation of several blood and urine parameters.

Luminescent biosensors to detect urinary infections:

The microorganisms in the urine, causing urinary tract infections, can be detected by employing luminescent biosensors. For this purpose, the immobilized (or even free) enzyme namely luciferase is used. The microorganisms, on lysis release ATP which can be detected by the following reaction. The quantity of light output can be measured by electronic devices.

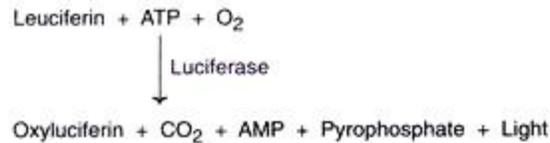

Other Optical Biosensors:

Optical fibre sensing devices are in use for measuring pH, pCO₂ and pO₂ in critical care, and surgical monitoring.

Piezoelectric Biosensors:

Piezoelectric biosensors are based on the principle of acoustics (sound vibrations), hence they are also called as acoustic biosensors. Piezoelectric crystals form the basis of these biosensors. The crystals with positive and negative charges vibrate with characteristic frequencies. Adsorption of certain molecules on the crystal surface alters the resonance frequencies which can be measured by electronic devices. Enzymes with gaseous substrates or inhibitors can also be attached to these crystals.

A piezoelectric biosensor for organophosphorus insecticide has been developed incorporating acetylcholine esterase. Likewise, a biosensor for formaldehyde has been developed by incorporating formaldehyde dehydrogenase. A biosensor for cocaine in gas phase has been created by attaching cocaine antibodies to the surface of piezoelectric crystal.

Limitations of Piezoelectric Biosensors:

It is very difficult to use these biosensors to determine substances in solution. This is because the crystals may cease to oscillate completely in viscous liquids.

Whole Cell Biosensors:

Whole cell biosensors are particularly useful for multi-step or cofactor requiring reactions. These biosensors may employ live or dead microbial cells. A selected list of some organisms along with the analytes and the types of biosensors used is given in Table 21.8

TABLE 21.8 A selected list of organisms along with the analytes and the types of biosensors

<i>Organism</i>	<i>Analyte</i>	<i>Type of biosensor</i>
<i>Escherichia coli</i>	Glutamate	Potentiometric (CO ₂)
<i>Sarcina flava</i>	Glutamine	Potentiometric (NH ₃)
<i>Proteus morganii</i>	Cysteine	Potentiometric (H ₂ S)
<i>Nitrosomanas sp</i>	Ammonia	Amperometric (O ₂)
<i>Lactobacillus fermenti</i>	Thiamine	Amperometric (mediated)
<i>Lactobacillus arabinosus</i>	Nicotinic acid	Potentiometric (H ⁺)
<i>Desulfovibrio desulfuricans</i>	Sulfate	Potentiometric (SO ₃ ⁻)
Cyanobacteria	Herbicides	Amperometric (mediated)
Many organisms	Biological oxygen demand (BOD)	Amperometric (O ₂)

Advantages of microbial cell biosensors:

The microbial cells are cheaper with longer half-lives. Further, they are less sensitive to variations in pH and temperature compared to isolated enzymes.

Limitations of microbial cell biosensors:

The whole cells, in general, require longer periods for catalysis. In addition, the specificity and sensitivity of whole cell biosensors may be lower compared to that of enzymes.

Immuno-Biosensors:

Immuno-biosensors or immunochemical biosensors work on the principle of immunological specificity, coupled with measurement (mostly) based on amperometric or potentiometric biosensors. There are several possible configurations for immuno-biosensors and some of them are depicted in Fig. 21.18, and briefly described hereunder.

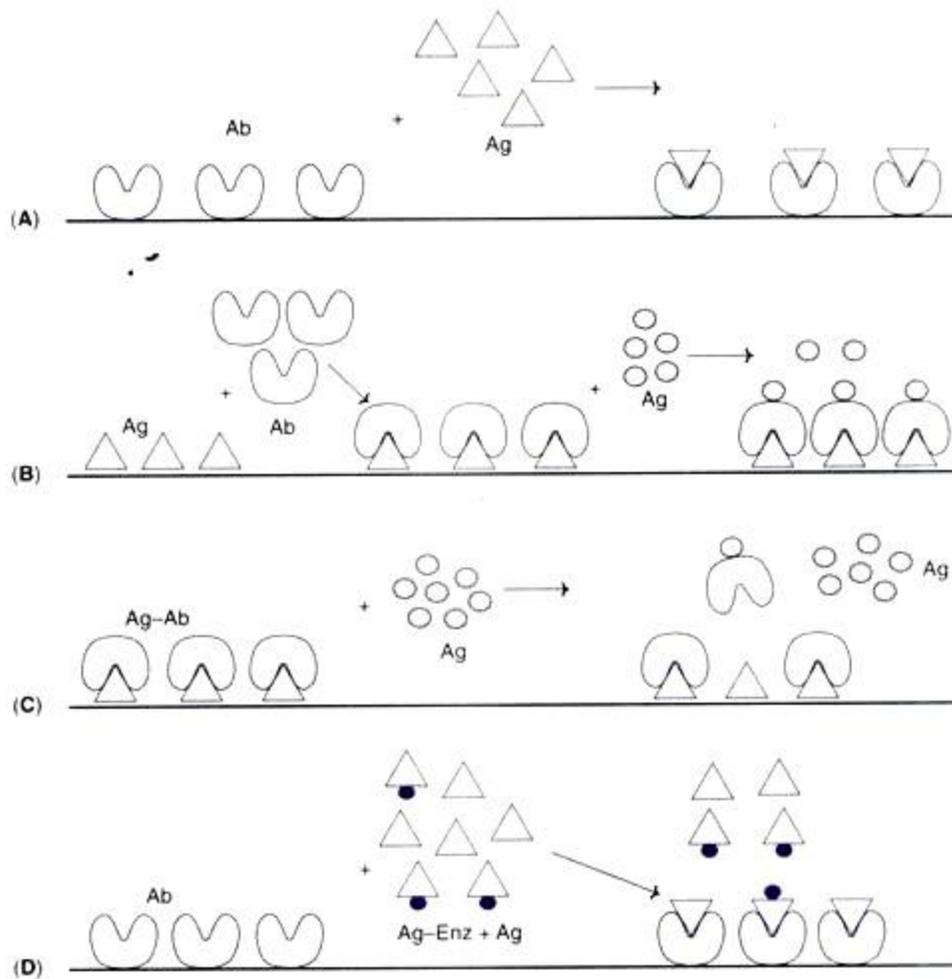

Fig. 21.18 : Diagrammatic representation of selected immunobiosensors (A) Direct binding of antigen to immobilized antibody, (B) Antigen-antibody sandwiches (immobilized antigen binds to antibody and then to a second antigen), (C) Antibody binds to immobilized antigen which gets partially released by a competitive free antigen, (D) Immobilized antibody binds to free antigen and enzyme labeled antigen (in competition).

1. An immobilized antibody to which antigen can directly bind (Fig. 21.18A).
2. An immobilized antigen that binds to antibody which in turn can bind to a free second antigen (Fig. 21.18B).
3. An antibody bound to immobilized antigen which can be partially released by competing with free antigen (Fig. 21.18C).

4. An immobilized antibody binding free antigen and enzyme labeled antigen in competition (Fig. 21.18D).

For the biosensors 1-3, piezoelectric devices can be used. The immuno-biosensors using enzymes (4 above, Fig. 21.18D) are the most commonly used. These biosensors employ thermometric or amperometric devices. The activity of the enzymes bound to immuno-biosensors is dependent on the relative concentrations of the labeled and unlabeled antigens. The concentration of the unlabeled antigen can be determined by assaying the enzyme activity.

UNIT V

OTHER SENSORS

Piezoelectric Transducer:

A piezoelectric crystal transducer/sensor is an active sensor and it does not need the help of an external power as it is self-generating. It is important to know the basics of a piezoelectric quartz crystal and piezoelectric effect before going into details about the transducer.

Piezoelectric Quartz Crystal

A quartz crystal is a piezoelectric material that can generate a voltage proportional to the stress applied upon it. For the application, a natural quartz crystal has to be cut in the shape of a thin plate of rectangular or oval shape of uniform thickness. Each crystal has three sets of axes – Optical axes, three electrical axes OX_1 , OX_2 , and OX_3 with 120 degree with each other, and three mechanical axes OY_1 , OY_2 and OY_3 also at 120 degree with each other. The mechanical axes will be at right angles to the electrical axes. Some of the parameters that decide the nature of the crystal for the application are

Angle at which the wafer is cut from natural quartz crystal

Plate thickness

Dimension of the plate

Means of mounting

Piezoelectric Effect

The X-Y axis of a piezoelectric crystal and its cutting technique is shown in the figure below.

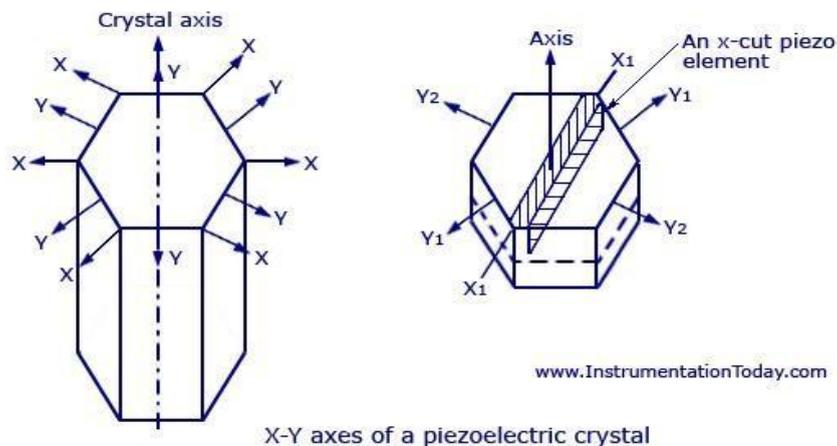

X-Y axes of a piezoelectric crystal

X-Y Axes of a Piezoelectric Crystal

The direction, perpendicular to the largest face, is the cut axis referred to.

If an electric stress is applied in the directions of an electric axis (X-axis), a mechanical strain is produced in the direction of the Y-axis, which is perpendicular to the relevant X-axis. Similarly, if a mechanical strain is given along the Y-axis, electrical charges will be produced on the faces of the crystal, perpendicular to the X-axis which is at right angles to the Y-axis.

Some of the materials that inherit piezo-electric effect are quartz crystal, Rochelle salt, barium titanate, and so on. The main advantages of these crystals are that they have high mechanical and thermal state capability, capability of withstanding high order of strain, low leakage, and good frequency response, and so on.

A piezoelectric transducer may be operated in one of the several modes as shown in the figure below.

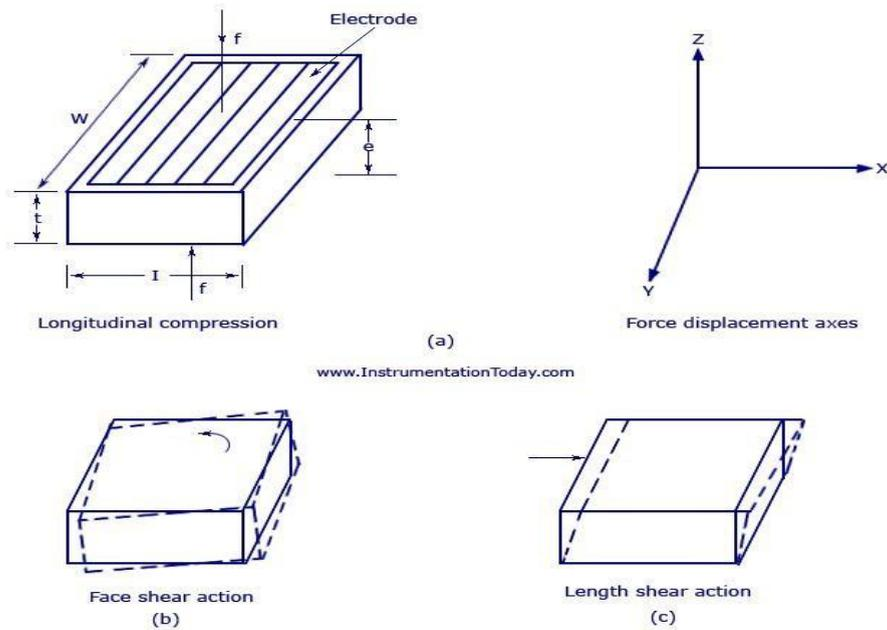

Piezoelectric Crystal

Piezoelectric Transducer

The main principle of a piezoelectric transducer is that a force, when applied on the quartz crystal, produces electric charges on the crystal surface. The charge thus produced can be called as piezoelectricity. Piezo electricity can be defined as the electrical polarization produced by mechanical strain on certain class of crystals. The rate of charge produced will be proportional to the rate of change of force applied as input. As the charge produced is very small, a charge amplifier is needed so as to produce an output voltage big enough to be measured. The device is also known to be mechanically stiff. For example, if a force of 15 kiloN is given to the transducer, it may only deflect to a maximum of 0.002mm. But the output response may be as high as 100KiloHz. This proves that the device is best applicable for dynamic measurement.

The figure shows a conventional piezoelectric transducer with a piezoelectric crystal inserted between a solid base and the force summing member. If a force is applied on the pressure port, the same force will fall on the force summing member. Thus a potential difference will be generated on the crystal due to its property. The voltage produced will be proportional to the magnitude of the applied force.

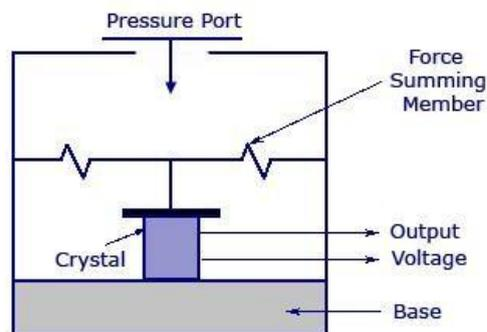

Piezo-Electric Transducer

Piezoelectric Transducer can measure pressure in the same way a force or an acceleration can be measured. For low pressure measurement, possible vibration of the amount should be compensated for. The pressure measuring quartz disc stack faces the pressure through a diaphragm and on the other side of this stack, the compensating mass followed by compensating quartz.

Applications

1. Due to its excellent frequency response, it is normally used as an accelerometer, where the output is in the order of (1-30) mV per gravity of acceleration.
2. The device is usually designed for use as a pre-tensional bolt so that both tensional and compression force measurements can be made.
3. Can be used for measuring force, pressure and displacement in terms of voltage.

Advantages

1. Very high frequency response.
2. Self generating, so no need of external source.
3. Simple to use as they have small dimensions and large measuring range.
4. Barium titanate and quartz can be made in any desired shape and form. It also has a large dielectric constant. The crystal axis is selectable by orienting the direction of orientation.

Disadvantages

1. It is not suitable for measurement in static condition.
2. Since the device operates with the small electric charge, they need high impedance cable for electrical interface.
3. The output may vary according to the temperature variation of the crystal.
4. The relative humidity rises above 85% or falls below 35%, its output will be affected. If so, it has to be coated with wax or polymer material.

Phototransistor

The phototransistor has a light sensitive collector to base junction. A lens is used in a transistor package to expose base to an incident light. When no light is incident, a small leakage current flows from collector to emitter called I_{CEO} , due to small thermal generation. This is very small current, of the order of nA. This is called a **dark current**.

When the base is exposed to the light, the base current is produced which is proportional to the light intensity. Such photoinduced base current is denoted as I_{λ} . The resulting collector current is given by,

$$I_C = h_{fe} I_{\lambda}$$

The structure of a phototransistor is shown in the Fig. while the symbol is shown in the Fig.

To generate more base current proportional to the light, larger physical area of the base is exposed to the light.

phototransistor. As light intensity increases, the base current increases exponentially. Similarly the collector current also increases corresponding to the increase in the light intensity.

A phototransistor can be either a two lead or a three lead device. In a three lead device, the base lead is brought out so that it can be used as a conventional BJT with or without the light sensitivity feature.

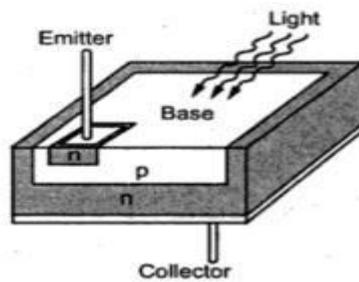

(a) Construction

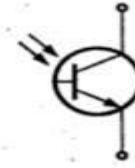

(b) Symbol

Elastic sensing elements

If a force is applied to a spring, then the amount of extension or compression of the spring is approximately proportional to the applied force. This is the principle of elastic sensing elements which convert an input force into an output displacement. Elastic elements are also commonly used for measuring torque, pressure and acceleration which are related to force by the equations:

$$\text{torque} = \text{force} \times \text{distance}$$

$$\text{pressure} = \frac{\text{force}}{\text{area}}$$

$$\text{acceleration} = \frac{\text{force}}{\text{mass}}$$

In a measurement system an elastic element will be followed by a suitable secondary displacement sensor, e.g. potentiometer, strain gauge, LVDT, which converts displacement into an electrical signal. The displacement may be translational or rotational.

Models of elastic elements:

- Linear accelerometer

- Pressure sensor

- Angular accelerometer

- Torque sensor

Practical elastic sensing elements

- Cantilever Load Cell

- Pillar Load Cell

- Torque Sensor

- Unbounded Strain Gauge Accelerometer

Magnetostrictive transducers

Magnetostriction

Magnetostriction can be explained as the corresponding change in length per unit length produced as a result of magnetization. The material should be magnetostrictive in nature. This phenomenon is known as Magnetostrictive Effect. The same effect can be reversed in the sense that, if an external force is applied on a magnetostrictive material, there will be a proportional change in the magnetic state of the material. This property was first discovered by James Prescott Joule by noticing the change in length of the material according to the change in magnetization. He called the phenomenon as Joule effect. The reverse

process is called Villari Effect or Magnetostrictive effect. This effect explains the change in magnetization of a material due to the force applied. Joule effect is commonly applied in magnetostrictive actuators and Villari effect is applied in magnetostrictive sensors.

This process is highly applicable as a transducer as the magnetostriction property of a material does not degrade with time.

Magnetostriction Transducers

A magnetostriction transducer is a device that is used to convert mechanical energy into magnetic energy and vice versa. Such a device can be used as a sensor and also for actuation as the transducer characteristics is very high due to the bi-directional coupling between mechanical and magnetic states of the material.

This device can also be called as an electro-magneto mechanical device as the electrical conversion to its appropriate mechanical energy is done by the device itself. In other devices, this operation is carried out by passing a current into a wire conductor so as to produce a magnetic field or measuring current induced by a magnetic field to sense the magnetic field strength.

Working

The figure below describes the exact working of a magnetostrictive transducer. The different figures explain the amount of strain produced from null magnetization to full magnetization. The device is divided into discrete mechanical and magnetic attributes that are coupled in their effect on the magnetostrictive core strain and magnetic induction.

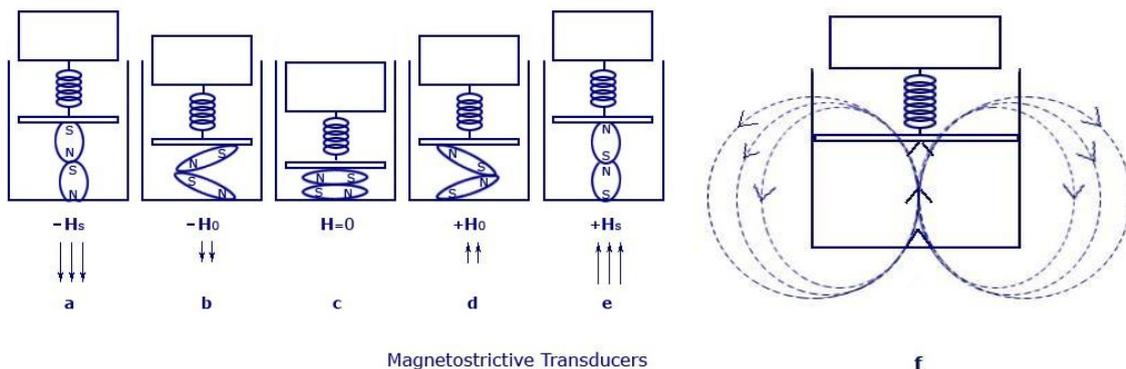

Magnetostrictive Transducers

First, considering the case where no magnetic field is applied to the material. This is shown in fig.c. Thus, the change in length will also be null along with the magnetic induction produced. The amount of the magnetic field (H) is increased to its saturation limits ($\pm H_{sat}$). This causes an increase in the axial strain to “ ϵ_{sat} ”. Also, there will be an increase in the value of the magnetization to the value $+B_{sat}$ (fig.e) or decreases to $-B_{sat}$ (fig.a). The maximum strain saturation and magnetic induction is obtained at the point when the value of H_s is at its maximum. At this point, even if we try to increase the value of field, it will not bring any change in the value of magnetization or field to the device. Thus, when the field value hits saturation, the values of strain and magnetic induction will increase moving from the center figure outward.

Let us consider another instance, where the value of H_s is kept fixed. At the same time, if we increase the amount of force on the magnetostrictive material, the compressive stress in the material will increase on to the opposite side along with a reduction in the values of axial strain and axial magnetization.

In fig.c, there are no flux lines present due to null magnetization. Fig.b and fig.d has magnetic flux lines in a much lesser magnitude, but according to the alignment of the magnetic domains in the magnetostrictive driver. Fig.a also has flux lines in the same design, but its flow will be in the opposite direction. Fig.f shows the flux lines according to the applied field H_s and the placing of the magnetic domains. These flux fields produced are measured using the principle of Hall Effect or by calculating the voltage produced in a conductor kept in right angle to the flux produced. This value will be proportional to the input strain or force.

Applications

The applications of this device can be divided into two modes. That is, one implying Joule Effect and the other are Villari Effect.

In the case where magnetic energy is converted to mechanical energy it can be used for producing force in the case of actuators and can be used for detecting magnetic field in the case of sensors.

If mechanical energy is converted to magnetic energy it can be used for detecting force or motion.

In early days, this device was used in applications like torque meters, sonar scanning devices, hydrophones, telephone receivers, and so on. Nowadays, with the invent of “giant” magnetostrictive alloys, it is being used in making devices like high force linear motors, positioners for adaptive optics, active vibration or noise control systems, medical and industrial ultrasonic, pumps, and so on. Ultrasonic magnetostrictive transducers have also been developed for making surgical tools, underwater sonar, and chemical and material processing.